

# ICC-ES Evaluation Report

ESR-2615

Reissued December 2023

This report also contains:



- FBC Supplement

Subject to renewal December 2024

- LABC Supplement

ICC-ES Evaluation Reports are not to be construed as representing aesthetics or any other attributes not specifically addressed, nor are they to be construed as an endorsement of the subject of the report or a recommendation for its use. There is no warranty by ICC Evaluation Service, LLC, express or implied, as to any finding or other matter in this report, or as to any product covered by the report.

Copyright © 2023 ICC Evaluation Service, LLC. All rights reserved.

<p><b>DIVISION: 06 00 00—</b> <b>WOOD, PLASTICS, AND COMPOSITES</b></p> <p><b>Section: 06 05 23—</b> <b>Wood, Plastic, and Composite Fastenings</b></p>	<p><b>REPORT HOLDER:</b> <b>SIMPSON STRONG-TIE COMPANY INC.</b></p> 	<p><b>EVALUATION SUBJECT:</b> <b>SIMPSON STRONG-TIE® TOP-FLANGE HANGERS FOR ENGINEERED WOOD PRODUCTS (EWP) AND GLULAM BEAMS</b></p>	
---	---	---	---

## 1.0 EVALUATION SCOPE

Compliance with the following codes:

- 2021, 2018, 2015, 2012 and 2009 [International Building Code® \(IBC\)](#)
- 2021, 2018, 2015, 2012 and 2009 [International Residential Code® \(IRC\)](#)

For evaluation for compliance with codes adopted by the [Los Angeles Department of Building and Safety \(LADBS\)](#), see [ESR-2615 LABC and LARC Supplement](#).

**Property evaluated:**

Structural

## 2.0 USES

The Simpson Strong-Tie® EWP top-flange hangers described in this report are used as wood framing connectors in accordance with Section [2304.10.4](#) of the 2021 IBC, Section [2304.10.3](#) of the 2018 and 2015 IBC (Section [2304.9.3](#) of the 2012 and 2009 IBC). The products may also be used in structures regulated under the IRC when an engineered design is submitted in accordance with Section [R301.1.3](#) of the IRC.

## 3.0 DESCRIPTION

### 3.1 General:

The EWP top-flange hangers recognized in this report have a U-shaped stirrup that is designed to support wood beams or joists and a top flange angle that is designed to bear onto a supporting wood or steel member. Descriptions of each series recognized in this report are given in Sections 3.1.1 through 3.1.9. A complete list of model numbers recognized within each series is given in [ESR-2523](#). For each specific model number, the dimensions of the intended joist width, height and number of face-to-face joist plies (where applicable) are indicated within the model numbers themselves, using one of the following numbering schemes:

- SERIES W/H or SERIES WH; where “SERIES” is the series designation, “W” is the joist width qualifier, and “H” is the height qualifier.
- SERIES WH-N; where “SERIES” is the series designation, “W” is the width qualifier for each joist ply, “H” is the height qualifier, and “N” is the number of joist plies.

- SERIES W; where “SERIES” is the series designation, and “W” is the joist width qualifier.

**3.1.1 GLTV and HGLTV Series Hangers:** The GLTV and HGLTV series hangers have a No. 7 gage U-shaped steel stirrup that is factory-welded to a No. 3 gage steel angle that acts as the top flange of the hanger. The HGLTV is similar to the GLTV except that the top flange dimension, nailing schedule and welds are increased. See [Table 1](#) for hanger model numbers, hanger seat width ranges, hanger height ranges, fastener schedules, and allowable loads. See [Figure 1](#) for the dimensions of the welded top flange angle and a drawing of a typical GLTV.

**3.1.2 WP Series Hangers:** The WP series hangers have a No. 7 gage steel angle top flange and a No. 12 gage steel U-shaped stirrup. See [Table 2](#) for hanger model numbers, hanger seat width ranges, hanger height ranges, required fastener schedules and allowable loads. See [Figure 2](#) for a drawing of a typical WP hanger.

**3.1.3 HGLT Series Hangers:** The HGLT series hangers have a No. 7 gage steel U-shaped stirrup that is factory-welded to a No. 3 gage steel angle. See [Table 3](#) for hanger model numbers, hanger seat width ranges, hanger height ranges, required fastener schedules and allowable loads. See [Figure 3](#) for a drawing of a HGLT hanger.

**3.1.4 GLS and HGLS Series Hangers:** The GLS and HGLS series hangers are saddle hangers that have a No. 7 gage steel U-shaped stirrup welded to each side of a No. 3 gage steel channel. The top channel bears onto a carrying beam and the two opposing stirrups support carried beams. The HGLS series hangers also have a steel plate welded to the lower portion of the U-shaped stirrup for additional fasteners installed into the supporting beam. See [Table 4](#) for hanger model numbers, hanger seat width ranges, hanger height ranges, channel width ranges, required fastener schedules, and allowable loads. See [Figure 4](#) for a drawing of a typical HGLS.

**3.1.5 EG, MEG, and LEG Series Hangers:** The EG, MEG, and LEG series hangers have a No. 7 gage steel U-shaped stirrup factory-welded to a No. 3 gage steel angle for the EG model, and to a No. 7 gage steel angle for the MEG and LEG models. See [Table 5](#) for the hanger model numbers, hanger seat width ranges, hanger height ranges, required fastener schedules, and allowable loads. See [Figure 5](#) for a drawing of an EG hanger and MEG and LEG hangers.

**3.1.6 ITS, MIT, and HIT Series Joist Hangers:** The ITS, MIT and HIT series joist hangers are used to connect prefabricated wood I-joists to a supporting wood beam. The ITS series joist hangers are die-formed from 18 gage galvanized steel, and have two large prongs at the seat that are used to resist uplift forces. The MIT and HIT series joist hangers are die-formed from No. 16 gage galvanized steel, and include 45-degree-angle nail openings, for attachment of the joist flange to the hanger. See [Table 6](#) for model numbers, hanger seat width ranges, hanger height ranges, required fastener schedules and allowable loads. See [Figure 6](#) for drawings of typical ITS, MIT and HIT hangers.

**3.1.7 HB and BA Series Hangers:** The BA series joist hangers are formed from No. 14 gage minimum thickness galvanized steel. The HB series joist hangers are formed from No. 10 gage galvanized steel. See [Table 7](#) for model numbers, hanger seat width ranges, hanger height ranges, required fastener schedules, and allowable loads. See [Figure 7](#) for drawings of HB and BA series hangers and typical installations.

**3.1.8 EGQ Series Hangers:** The EGQ series hangers have a No. 7 gage steel U-shaped stirrup that is factory-welded to a No. 3 gage steel angle that acts as the top flange of the hanger. The hangers are installed using Simpson Strong-Drive SDS series wood screws (SDS), which are recognized under [ESR-2236](#). See [Table 8](#) for model numbers, hanger dimensions, fastener schedules, and allowable loads. See [Figure 8](#) for a drawing of the EGQ hanger and a typical installation.

**3.1.9 HWP and HWPH Series Hangers:** The HWP series hangers have a No. 7 gage steel angle top flange and a No. 12 gage steel U-shaped stirrup welded to the top flange. The HWPH series hanger have a No. 3 gage steel angle top flange and a No. 7 gage steel U-shaped stirrup welded to the top flange. See [Table 9](#) for hanger model number, hanger seat width ranges, hanger height ranges, required fastener schedules and allowable loads. See [Figure 9](#) for typical HWP and HWPH hangers and a drawing of a typical installation of an HWPH hanger.

## 3.2 Materials:

**3.2.1 Steel:** The ITS, MIT, HIT, BA and HB series hangers described in this report are manufactured from galvanized steel complying with [ASTM A653](#), SS designation Grade 33, with a minimum yield strength,  $F_y$ , of 33,000 psi (227 MPa) and a minimum ultimate tensile strength,  $F_u$ , of 45,000 psi (310 MPa). The remaining hangers described in this report are manufactured from ungalvanized steel complying with [ASTM A1011](#),

SS designation Grade 33, with a minimum yield strength,  $F_y$ , of 33,000 psi (227 MPa) and a minimum tensile strength,  $F_u$ , of 52,000 psi (359 MPa). The minimum base-metal thicknesses for the hangers in this report are as follows:

NOMINAL THICKNESS (gage)	MINIMUM BASE-METAL THICKNESS (inch)
No. 3	0.2285
No. 7	0.1705
No. 10	0.1275
No. 12	0.0975
No. 14	0.0685
No. 16	0.0555
No. 18	0.0445

For SI: 1 inch = 25.4 mm.

The hangers manufactured from galvanized steel have a minimum G90 zinc coating specification in accordance with [ASTM A924](#) and ASTM A653. The hangers manufactured from ungalvanized steel have either a painted or powder coated finish. Some models (designated with a model number ending with Z) are available with a G185 zinc coating specification in accordance with ASTM A653. Some models (designated with a model number ending with HDG) are available with a batch hot-dipped galvanized coating with a minimum specified coating weight of 2.0 ounces of zinc per square foot of surface area (600 g/m<sup>2</sup>), total for both sides, in accordance with [ASTM A123](#). Model numbers in this report do not include the Z or HDG ending, but the information shown applies. The lumber treatment manufacturer or the report holder (Simpson Strong-Tie Company) should be contacted for recommendations on minimum corrosion resistance protection of steel connectors in contact with the specific proprietary preservative-treated or fire-retardant treated lumber.

**3.2.2 Wood:** Wood members with which the connectors are used must be either sawn lumber or engineered lumber (structural composite lumber or structural glued laminated timber) having a minimum specific gravity of 0.50 (minimum equivalent specific gravity for fastener design of 0.50 for engineered lumber), and having a maximum moisture content of 19 percent (16 percent for engineered lumber) except as noted in Section [4.1](#). The thickness of the supporting wood member (header) must be equal to or greater than the length of the fasteners specified in the tables in this report, or as required by wood member design, whichever is greater.

**3.2.3 Fasteners:** The type, size and number of fasteners used to install the hangers described in this report must comply with the fastener schedules specified in [Tables 1](#) through [9](#). Simpson Strong-Drive SDS screws used for hangers described in this report must comply with [ESR-2236](#). Bolts used for hangers described in this report, at a minimum, must comply with [ASTM A36](#) or [ASTM A307](#) and must have a minimum bending yield strength ( $F_{yb}$ ) of 45,000 psi. Common nails used for hangers described in this report must comply with [ASTM F1667](#) and have the following minimum fastener dimensions and bending yield strengths ( $F_{yb}$ ):

FASTENER	SHANK DIAMETER (inches)	FASTENER LENGTH (inches)	$F_{yb}$ (psi)
10d × 1½	0.148	1½	90,000
10d	0.148	3	90,000
16d × 2½	0.162	2½	90,000
16d	0.162	3½	90,000
N54A <sup>1</sup>	0.250	2½	70,000

For SI: 1 inch = 25.4 mm, 1 psi = 6.89 kPa.

<sup>1</sup>N54A is a designation for proprietary annular ring shank nails supplied by Simpson Strong-Tie Company with the hangers described in [Tables 3](#) and [4](#) of this report.

Fasteners used in contact with preservative treated or fire retardant treated lumber must comply with Section [2304.10.5](#) of the 2018 and 2015 IBC (Section [2304.9.5](#) of the 2012, 2009 and 2006 IBC), Section [R317.3](#) of the 2018, 2015, 2012 and 2009 IRC, or, Section [R319.3](#) of the 2006 IRC, or [ESR-2236](#), as applicable. The lumber treatment manufacturer or this report holder (Simpson Strong-Tie Company) should be contacted for recommendations on minimum corrosion resistance protection of fasteners and connection capacities of fasteners used with the specific proprietary preservative treated or fire retardant treated lumber.



## 4.0 DESIGN AND INSTALLATION

### 4.1 Design:

The tabulated allowable loads shown in this report are based on allowable stress design (ASD) and include the load duration factor,  $C_D$ , corresponding with the applicable loads in accordance with the ANSI/AWC *National Design Specification*<sup>®</sup> for Wood Construction (NDS).

Tabulated allowable loads apply to products connected to wood used under dry conditions and where sustained temperatures are 100°F (37.8°C) or less. When products are installed to wood having a moisture content greater than 19 percent (16 percent for engineered wood products), or where wet service is expected, the allowable loads must be adjusted by the wet service factor,  $C_M$ , for dowel-type fasteners (NDS Section 11.3.3) for uplift loads, and as required for the product-specific adjustment (NDS *Supplement* or a current ICC-ES Evaluation Report) for compression perpendicular to grain for download. When connectors are installed in wood that will experience sustained exposure to temperatures exceeding 100°F (37.8°C), the allowable loads in this report must be adjusted by the temperature factor,  $C_t$ , specified in the NDS.

Connected wood members must be analyzed for load-carrying capacity at the connection in accordance with the NDS.

### 4.2 Installation:

Installation of the connectors must be in accordance with this evaluation report and the manufacturer's published installation instructions. In the event of a conflict between this report and the manufacturer's published installation instructions, this report governs.

### 4.3 Special Inspection:

**4.3.1 Main Wind-force-resisting Systems Under the IBC:** Periodic special inspection must be conducted in accordance with Sections [1704.2](#) and [1705.12](#) of 2021 IBC, the applicable sections of 2018 and 2015 IBC Section [1705.11](#), 2012 IBC Section [1705.10](#), or 2009 IBC Section [1706](#) when the connectors described in this report are used as components of the main wind-force-resisting system on structures in areas listed in Sections 1704.2 and 1705.12 of 2021 IBC, Section 1705.11 of the 2018 and 2015 IBC, Section 1705.10 of the 2012 IBC, or Section [1706.1](#) of the 2009 IBC. . Special inspection requirements do not apply to structures, or portions thereof, that qualify for the exceptions under Sections 1704.2 and 1705.12.1 of 2021 IBC, Sections [1704.2](#) and [1705.11.1](#) of the 2018 and 2015 IBC, Sections [1704.2](#) or [1705.10.1](#) of the 2012 IBC; Section [1704.1](#) or [1706.2](#) of the 2009 IBC.

**4.3.2 Seismic-force-resisting Systems Under the IBC:** Periodic special inspection must be conducted in accordance with Sections 1704.2 and [1705.13](#) of the 2021 IBC, the applicable parts of Section [1705.12](#) of the 2018 and 2015 IBC, Section [1705.11](#) of the 2012 IBC, or Section [1707](#) of the 2009 IBC, when the connectors described in this report are used as components of a seismic-force-resisting system for a structure in Seismic Design Category C, D, E or F. Special inspection requirements do not apply to structures, or portions thereof, that qualify for the exceptions under Sections 1704.2 and 1705.13 of the 2021 IBC, Section 1704.2 or 1705.11 of the 2012 IBC; or Section 1704.1, [1707.3](#) or [1707.4](#) of the 2009 IBC.

**4.3.3 Installations Under the IRC: For installations under** the IRC, special inspections are normally not required. However, for an engineered design where calculations are required to be signed by a registered design professional, periodic special inspection requirements and exemptions are as stated in Sections 4.3.1 and 4.3.2 of this report, as applicable, for installations under the IRC.

## 5.0 CONDITIONS OF USE:

The Simpson Strong-Tie EWP top-flange hangers described in this report comply with, or are suitable alternatives to what is specified in, those codes listed in Section [1.0](#) of this report, subject to the following conditions:

- 5.1 The connectors must be manufactured, identified and installed in accordance with this report and the manufacturer's published installation instructions. A copy of the instructions must be available at the jobsite at all times during installation.
- 5.2 Calculations showing compliance with this report must be submitted to the code official. The calculations must be prepared by a registered design professional where required by the statutes of the jurisdiction in which the project is to be constructed.
- 5.3 Adjustment factors noted in Section 4.1 and the applicable codes must be considered, where applicable.

- 5.4 Connected wood members and fasteners must comply, respectively, with Sections 3.2.2 and 3.2.3 of this report.
- 5.5 Use of connectors with preservative- or fireretardant-treated lumber must be in accordance with Section 3.2.1 of this report. Use of fasteners with preservative- or fire retardant-treated lumber must be in accordance with Section 3.2.3 of this report.
- 5.6 Factory welded hangers are manufactured under a quality-control program with inspections by ICC-ES.

## 6.0 EVIDENCE SUBMITTED

Data in accordance with the [ICC-ES Acceptance Criteria for Joist Hangers and Similar Devices \(AC13\)](#), dated October 2018 (editorially revised December 2020).

## 7.0 IDENTIFICATION

- 7.1 The products described in this report are identified with a die-stamped or adhesive label indicating the name of the manufacturer (Simpson Strong-Tie), the model number, and the number of an index evaluation report ([ESR-2523](#)) that is used as an identifier for the products recognized in this report.
- 7.2 The report holder’s contact information is the following:

**SIMPSON STRONG-TIE COMPANY INC.**  
**5956 WEST LAS POSITAS BOULEVARD**  
**PLEASANTON, CALIFORNIA 94588**  
**(800) 999-5099**  
[www.strongtie.com](http://www.strongtie.com)

TABLE 1—ALLOWABLE LOADS FOR THE GLTV/HGLTV SERIES HANGERS

SERIES <sup>1</sup>	HANGER DIMENSIONS <sup>1</sup> (inches)			FASTENERS (Quantity - Type)			ALLOWABLE LOADS <sup>2,3</sup> (lbs)			
				Header		Joist	Uplift <sup>4</sup>		Download	
	W	H	B	Top	Face		C <sub>D</sub> = 1.6	C <sub>D</sub> = 1.0	C <sub>D</sub> = 1.15	C <sub>D</sub> = 1.25
GLTV	3 1/4 - 7 1/8	11 - 32	5	4 - 16d	6 - 16d	6 - 16d	1,120	5,525	5,525	5,525
HGLTV	3 1/4 - 7 1/8	14 - 33	6	6 - 16d	12 - 16d	6 - 16d	1,120	7,805	7,805	7,805

For SI: 1 inch = 25.4 mm, 1 lbs = 4.45 N, 1 psi = 6.89 kPa.

<sup>1</sup>Refer to Figure 1 for definitions of hanger dimension nomenclature (W, H). The “B” dimension is the length of the hanger seat, measured perpendicular to the “W” dimension. Refer to [ESR-2523](#) for a complete list of all GLTV and HGLTV model numbers. See Section 3.1 for a description of model numbering schemes, as they relate to intended joist dimensions and number of joist plies.

<sup>2</sup>Tabulated allowable load capacities must be selected based on duration of load as permitted by the applicable building code. The allowable uplift loads have been increased for wind or earthquake loading with no further increase allowed. The allowable uplift loads must be reduced when other load durations govern.

<sup>3</sup>The allowable loads are based on the use of Douglas fir-larch header members with an allowable compression perpendicular-to-grain, F<sub>c⊥</sub>, of 625 psi, and structural composite lumber joists with an F<sub>c⊥</sub> of 750 psi. When the hangers are supported by header members having an F<sub>c⊥</sub> of less than 625 psi and/or are used to support joists having an F<sub>c⊥</sub> of less than 750 psi, it must be verified that the combination of bearing capacity and joist nail capacity is adequate.

<sup>4</sup>Uplift loads are not applicable to hanger heights, H, greater than 32 inches.

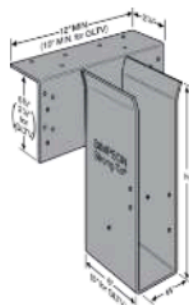

HGLTV Hanger

FIGURE 1—HGLTV AND GLTV SERIES HANGERS

TABLE 2—ALLOWABLE LOADS FOR THE WP SERIES HANGERS

SERIES <sup>1</sup>	HANGER DIMENSIONS <sup>1</sup> (inches)			FASTENERS (Quantity - Type)			ALLOWABLE LOADS <sup>2,3,4</sup> (lbs)	
	W	H	B	Top	Face	Joist	Uplift	Download
							C <sub>D</sub> =1.60	C <sub>D</sub> =1.00/ 1.15/1.25
WP	1 <sup>9</sup> / <sub>16</sub> - 7 <sup>1</sup> / <sub>8</sub>	5 <sup>3</sup> / <sub>8</sub> - 30	2 <sup>1</sup> / <sub>2</sub> - 6	4 - 10d x 2 <sup>1</sup> / <sub>2</sub>	—	2 - 10d x 1 <sup>1</sup> / <sub>2</sub>	—	2,985

For SI: 1 inch = 25.4 mm, 1 lbs = 4.45 N.

<sup>1</sup>Refer to Figure 2 for definitions of hanger dimension nomenclature (W, H, B). Refer to ESR-2523 for a complete list of all W model numbers. See Section 3.1 for a description of model numbering schemes, as they relate to intended joist dimensions and number of joist plies.

<sup>2</sup>Tabulated allowable loads must be selected based on duration of load as permitted by the applicable building code.

<sup>3</sup>The allowable loads are based on the use of Douglas fir-larch header members with an allowable compression perpendicular-to-grain, F<sub>c⊥</sub>, of 625 psi, and structural composite lumber joists with an F<sub>c⊥</sub> of 625 psi. When the hangers are supported by header members having an F<sub>c⊥</sub> of less than 625 psi and/or are used to support joists having an F<sub>c⊥</sub> of less than 625 psi, it must be verified that the combination of bearing capacity and joist nail capacity is adequate.

<sup>4</sup>For welding to steel headers use 3/16-inch-thick (root) by 1/2-inch-long fillet welds for WP models. Field welds shall be constructed and inspected in accordance with the applicable code.

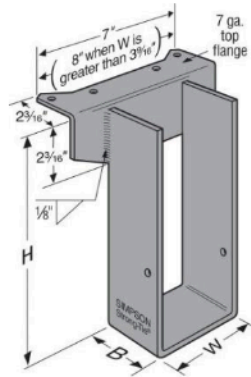

FIGURE 2—WP HANGER

TABLE 3—ALLOWABLE LOADS FOR THE HGLT SERIES HANGERS

SERIES <sup>1</sup>	HANGER DIMENSIONS <sup>1</sup> (inches)				FASTENERS <sup>3</sup> (Quantity - Type)			ALLOWABLE LOADS <sup>4,6,7,8</sup> (lbs)			
	W	H <sup>2</sup>	B	L	Header		Joist	Uplift <sup>2,5</sup>		Download	
					Top	Face		C <sub>D</sub> =1.60	C <sub>D</sub> =1.00	C <sub>D</sub> =1.15	C <sub>D</sub> =1.25
HGLT	3 <sup>1</sup> / <sub>4</sub> - 8 <sup>7</sup> / <sub>8</sub>	7 <sup>1</sup> / <sub>2</sub> - 32	6	12 - 14	6 - N54A	12 - N54A	6 - N54A	2,450	10,720	10,720	10,720

For SI: 1 inch = 25.4 mm, 1 lbs = 4.45 N, 1 psi = 6.89 kPa.

<sup>1</sup>Refer to Figure 3 for definitions of hanger dimension nomenclature (W, H, B, L). Refer to ESR-2523 for a complete list of all HGLT model numbers. See Section 3.1 for a description of model numbering schemes, as they relate to intended joist dimensions and number of joist plies.

<sup>2</sup>The H dimension must be specified. Tabulated uplift values are applicable to a maximum H of 28<sup>1</sup>/<sub>2</sub>".

<sup>3</sup>N54A fasteners are annular ring shank nails (0.250-inch dia. x 2<sup>1</sup>/<sub>2</sub>-inch long) and are supplied with the hangers.

<sup>4</sup>Tabulated allowable loads must be selected based on duration of load as permitted by the applicable building code.

<sup>5</sup>The uplift loads have been increased for wind or earthquake loading with no further increase allowed. The allowable uplift loads must be reduced when other load durations govern.

<sup>6</sup>The allowable loads are based on the use of Douglas fir-Larch header material with an allowable F<sub>c⊥</sub> of 625 psi and Douglas fir-Larch glulam joist material with an allowable F<sub>c⊥</sub> of 650 psi. For alternate joist material, verify that the combination of bearing capacity and joist nails is adequate.

<sup>7</sup>The connectors provide a torsional resistance up to a maximum joist depth of 32 inches, where torsional resistance is defined as a moment of not less than 75 pounds (334 N) times the depth of the joist at which the lateral movement of the top or bottom of the joist with respect to the vertical position of the joist is 0.125 inch (3.2 mm).

<sup>8</sup>The HGLT may be attached to steel headers by 1/4-inch-thick (root) by 2<sup>1</sup>/<sub>2</sub>-inch-long fillet welds located at each end of the header angle to obtain the lesser of the values tabulated for the HGLT or 12,000 pounds maximum. Field welds shall be constructed and inspected in accordance with the applicable code.

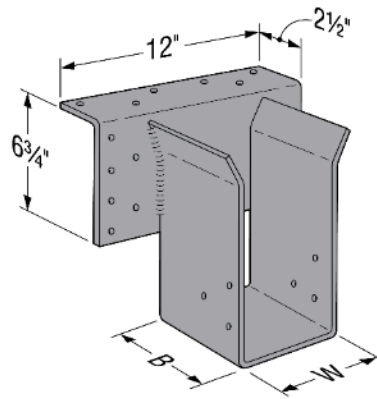

FIGURE 3—HGLT SERIES HANGERS

TABLE 4—ALLOWABLE LOADS FOR THE GLS AND HGLS SERIES HANGERS

SERIES <sup>1</sup>	HANGER DIMENSIONS <sup>1</sup> (inches)					FASTENERS <sup>4</sup> (Quantity - Type)		ALLOWABLE LOADS <sup>5,7,8</sup> (lbs)			
	W <sub>1</sub> , W <sub>2</sub>	H <sub>1</sub> , H <sub>2</sub> <sup>2</sup>	B	L	S	Face	Joist	Uplift <sup>6</sup>			
								C <sub>D</sub> = 1.60	C <sub>D</sub> = 1.00	C <sub>D</sub> = 1.15	C <sub>D</sub> = 1.25
GLS	3 <sup>1</sup> / <sub>4</sub>	8 <sup>1</sup> / <sub>2</sub> - 28	5	9	5 <sup>1</sup> / <sub>8</sub> - 8 <sup>3</sup> / <sub>4</sub>	6 - N54A	6 - N54A	2,265	8,620	8,620	8,620
GLS	5 <sup>1</sup> / <sub>4</sub> - 6 <sup>7</sup> / <sub>8</sub>	8 <sup>1</sup> / <sub>2</sub> - 28	5	9	5 <sup>1</sup> / <sub>8</sub> - 8 <sup>3</sup> / <sub>4</sub>	6 - N54A	6 - N54A	2,265	8,620	8,620	8,620
HGLS	5 <sup>1</sup> / <sub>4</sub> - 8 <sup>7</sup> / <sub>8</sub>	10 <sup>1</sup> / <sub>2</sub> - 28	6	12	SPEC <sup>3</sup>	14 - N54A	8 - N54A	2,265	13,850	13,850	13,850

For SI: 1 inch = 25.4 mm, 1 lbs = 4.45 N.

<sup>1</sup>Refer to Figure 4 for definitions of hanger dimension nomenclature (W, H, B, L, S). Refer to ESR-2523 for a complete list of all GLS and HGLS model numbers. See Section 3.1 for a description of model numbering schemes, as they relate to intended joist dimensions and number of joist plies.

<sup>2</sup>The H dimension must be specified.

<sup>3</sup>SPEC = The header (carrying beam) dimensions must be specified by the registered design professional.

<sup>4</sup>N54A fasteners are annular ring shank nails (0.250-inch dia. x 2<sup>1</sup>/<sub>2</sub>-inch long) and are supplied with the hangers. Tabulated fastener quantities reflect the number of fasteners that must be used on each side of the header (carrying beam).

<sup>5</sup>Tabulated allowable loads must be selected based on duration of load as permitted by the applicable building code.

<sup>6</sup>The uplift loads have been increased for wind or earthquake loading with no further increase allowed. The allowable uplift loads must be reduced when other load durations govern.

<sup>7</sup>The allowable loads are based on the use of Douglas fir glued-laminated material with an allowable compression perpendicular-to-grain stress, F<sub>c⊥</sub>, of 650 psi. For alternate joist material, verify that the combination of bearing capacity and joist nails is adequate.

<sup>8</sup>Allowable loads are per supported member (carried beam).

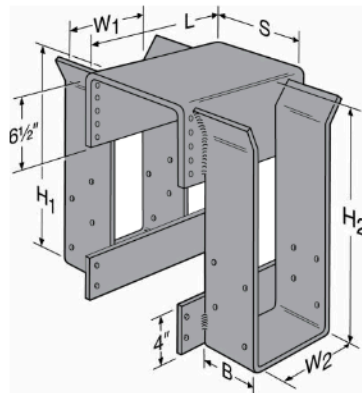

HGLS Beam Saddle Hanger

FIGURE 4—GLS AND HGLS SERIES HANGERS



TABLE 5—ALLOWABLE LOADS FOR THE EG, MEG AND LEG SERIES HANGERS

SERIES <sup>1</sup>	HANGER DIMENSIONS <sup>1</sup> (inches)					FASTENERS (Quantity - Bolt Diameter)		ALLOWABLE LOADS <sup>2,3,4,5</sup> (lbs)	
	W	H	B	L	TF	Face	Joist	Download	
								C <sub>D</sub> =1.00	C <sub>D</sub> =1.25
LEG3	3 <sup>1</sup> / <sub>4</sub>	9 – 33 <sup>1</sup> / <sub>2</sub>	6	12	2 <sup>1</sup> / <sub>2</sub>	4 - 3/4"	2 - 3/4"	13,045	13,870
LEG5	5 <sup>1</sup> / <sub>4</sub>	9 – 32 <sup>1</sup> / <sub>2</sub>	6	12	2 <sup>1</sup> / <sub>2</sub>	4 - 3/4"	2 - 3/4"	13,045	13,870
MEG5	5 <sup>1</sup> / <sub>4</sub>	9 – 32 <sup>1</sup> / <sub>2</sub>	6	12	2 <sup>1</sup> / <sub>2</sub>	6 - 3/4"	2 - 3/4"	14,515	14,515
EG5	5 <sup>1</sup> / <sub>4</sub>	11 – 32 <sup>1</sup> / <sub>2</sub>	6	11 <sup>3</sup> / <sub>4</sub>	2 <sup>1</sup> / <sub>2</sub>	8 - 1"	2 - 1"	17,895	19,875
LEG7	6 <sup>7</sup> / <sub>8</sub>	9 – 31 <sup>1</sup> / <sub>2</sub>	6	12	2 <sup>1</sup> / <sub>2</sub>	4 - 3/4"	2 - 3/4"	13,045	13,870
MEG7	6 <sup>7</sup> / <sub>8</sub>	9 – 31 <sup>1</sup> / <sub>2</sub>	6	12	2 <sup>1</sup> / <sub>2</sub>	6 - 3/4"	2 - 3/4"	14,515	14,515
EG7	6 <sup>7</sup> / <sub>8</sub>	11 – 31 <sup>1</sup> / <sub>2</sub>	6	13 <sup>1</sup> / <sub>2</sub>	2 <sup>1</sup> / <sub>2</sub>	8 - 1"	2 - 1"	19,305	21,300
EG9	8 <sup>7</sup> / <sub>8</sub>	11 – 30 <sup>1</sup> / <sub>2</sub>	6	15 <sup>1</sup> / <sub>2</sub>	2 <sup>1</sup> / <sub>2</sub>	8 - 1"	2 - 1"	20,895	22,895

For SI: 1 inch = 25.4 mm, 1 lb = 4.45 N.

<sup>1</sup>Refer to Figure 5 for definitions of hanger dimension nomenclature (W, H, B, L, TF). Refer to ESR-2523 for a complete list of all EG, MEG and LEG model numbers. See Section 3.1 for a description of model numbering schemes, as they relate to intended joist dimensions and number of joist plies.

<sup>2</sup>Tabulated loads require the use of a minimum 5<sup>1</sup>/<sub>8</sub>-inch-wide header (carrying member).

<sup>3</sup>Tabulated allowable loads must be selected based on duration of load as permitted by the applicable building code.

<sup>4</sup>The allowable loads are based on the use of Douglas fir-Larch header material with an allowable F<sub>cL</sub> of 625 psi and Douglas fir-Larch glulam joist material with an allowable F<sub>cL</sub> of 650 psi. For alternate joist material, verify that the combination of bearing capacity and joist nails is adequate.

<sup>5</sup>Uplift loads for these hangers are beyond the scope of this report.

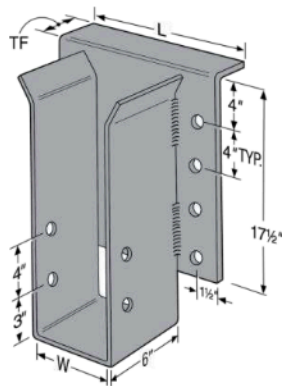

EG Beam Hanger

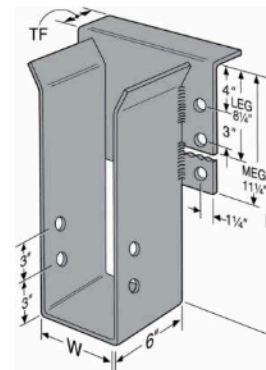

LEG and MEG Beam Hanger

FIGURE 5—EG, MEG AND LEG SERIES HANGERS



TABLE 6—ALLOWABLE LOADS FOR THE ITS, MIT AND HIT HANGER SERIES MODELS

SERIES <sup>1</sup>	HANGER DIMENSIONS <sup>1</sup> (inches)				FASTENERS (Quantity - Type)			ALLOWABLE LOADS <sup>2,4</sup> (lbs)			
								Uplift <sup>3</sup>	Download		
	W	H	B	TF	Top	Face	Joist	C <sub>D</sub> = 1.60	C <sub>D</sub> = 1.00	C <sub>D</sub> = 1.15	C <sub>D</sub> = 1.25
ITS	1 <sup>9</sup> / <sub>16</sub> to 3 <sup>5</sup> / <sub>8</sub>	9 <sup>1</sup> / <sub>8</sub> to 16	2	1 <sup>7</sup> / <sub>16</sub>	4 - 10d x 1 <sup>1</sup> / <sub>2</sub>	2 - 10d x 1 <sup>1</sup> / <sub>2</sub>	—	120	1,455	1,455	1,455
					4 - 10d	2 - 10d	—	120	1,470	1,470	1,470
					4 - 16d	2 - 16d	—	120	1,565	1,565	1,565
MIT	1 <sup>9</sup> / <sub>16</sub> to 5 <sup>1</sup> / <sub>8</sub>	9 <sup>1</sup> / <sub>4</sub> to 24	2 <sup>1</sup> / <sub>2</sub>	2 <sup>5</sup> / <sub>16</sub>	4 - 10d x 1 <sup>1</sup> / <sub>2</sub>	4 - 10d x 1 <sup>1</sup> / <sub>2</sub>	2 - 10d x 1 <sup>1</sup> / <sub>2</sub>	215	2,275	2,275	2,275
					4 - 10d	4 - 10d	2 - 10d x 1 <sup>1</sup> / <sub>2</sub>	215	2,570	2,570	2,570
					4 - 16d	4 - 16d	2 - 10d x 1 <sup>1</sup> / <sub>2</sub>	215	2,575	2,575	2,575
HIT	2 <sup>5</sup> / <sub>16</sub> to 3 <sup>9</sup> / <sub>16</sub>	18 to 26	3	2 <sup>3</sup> / <sub>8</sub> to 3	4 - 16d	6 - 16d	2 - 10d x 1 <sup>1</sup> / <sub>2</sub>	305	2,875	2,875	2,875

For SI: 1 inch = 25.4 mm, 1 pound = 4.45 N.

<sup>1</sup>Refer to Figure 6 (this page) for definitions of hanger nomenclature (W, H, B, TF). Refer to ESR-2523 for a complete list of all ITS, MIT and HIT model numbers. See Section 3.1 for a description of model numbering schemes, as they relate to intended joist dimensions and number of joist plies.

<sup>2</sup>Tabulated allowable loads must be selected based on duration of load as permitted by the applicable building code.

<sup>3</sup>The uplift loads have been increased for wind or earthquake loading with no further increase allowed. The allowable uplift loads must be reduced when other load durations govern, except for those associated with the ITS which need not be reduced when other load durations govern.

<sup>4</sup>The allowable loads are based on the use of Douglas fir-Larch material with an allowable F<sub>cL</sub> of 625 psi. For alternate joist material, verify that the combination of bearing capacity and joist nails (MIT and HIT only) is adequate.

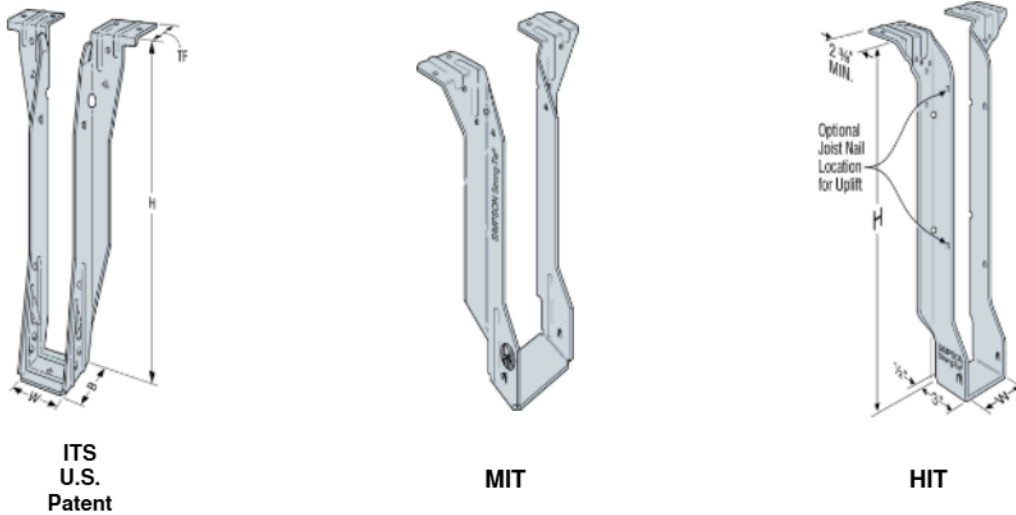

FIGURE 6—ITS, MIT AND HIT HANGERS

TABLE 7—ALLOWABLE LOADS FOR BA AND HB SERIES JOIST HANGERS

SERIES <sup>1</sup>	HANGER DIMENSIONS <sup>1</sup> (inches)				FASTENERS (Quantity - Type)			ALLOWABLE LOADS <sup>2,4,5</sup> (lbs)			
	W	H	B	TF	Top	Face	Joist <sup>5</sup>	Uplift <sup>3,6</sup>	Download		
								C <sub>D</sub> = 1.60	C <sub>D</sub> = 1.00	C <sub>D</sub> = 1.15	C <sub>D</sub> = 1.25
BA	1 <sup>9</sup> / <sub>16</sub> - 7 <sup>1</sup> / <sub>8</sub>	7 <sup>1</sup> / <sub>8</sub> - <11	3	2 <sup>5</sup> / <sub>16</sub>	6 - 16d	10 - 16d	2 - 10d x 1 <sup>1</sup> / <sub>2</sub>	255	3,205	3,205	3,205
	1 <sup>9</sup> / <sub>16</sub> - 7 <sup>1</sup> / <sub>8</sub>	11 - 30	3	2 <sup>5</sup> / <sub>16</sub>	6 - 16d	10 - 16d	2 - 10d x 1 <sup>1</sup> / <sub>2</sub>	255	3,780	3,780	3,780
	1 <sup>9</sup> / <sub>16</sub>	7 <sup>1</sup> / <sub>8</sub> - 30	3	2 <sup>5</sup> / <sub>16</sub>	6 - 16d	10 - 16d	8 - 10d x 1 <sup>1</sup> / <sub>2</sub>	1,275	4,645	4,645	4,645
	1 <sup>13</sup> / <sub>16</sub> - 7 <sup>1</sup> / <sub>8</sub>	7 <sup>1</sup> / <sub>8</sub> - 30	3	2 <sup>5</sup> / <sub>16</sub>	6 - 16d	10 - 16d	8 - 10d x 1 <sup>1</sup> / <sub>2</sub>	1,275	4,720	4,720	4,720
HB	1 <sup>9</sup> / <sub>16</sub> - 2 <sup>1</sup> / <sub>2</sub>	8 - 30	3 <sup>1</sup> / <sub>2</sub> - 5	3	6 - 16d	16 - 16d	10 - 10d x 1 <sup>1</sup> / <sub>2</sub>	2,210	5,810	5,965	6,065
	2 <sup>9</sup> / <sub>16</sub> - 3 <sup>1</sup> / <sub>2</sub>	8 - 30	3 <sup>1</sup> / <sub>2</sub>	3	6 - 16d	16 - 16d	10 - 16d x 2 <sup>1</sup> / <sub>2</sub>	1,560	5,650	5,650	5,650
	3 <sup>9</sup> / <sub>16</sub> - 7 <sup>1</sup> / <sub>2</sub>	8 - 30	3 <sup>1</sup> / <sub>2</sub>	3	6 - 16d	16 - 16d	10 - 16d	2,075	5,395	5,395	5,395

For SI: 1 inch = 25.4 mm, 1 pound = 4.45 N.

<sup>1</sup>Refer to Figure 7 (this page) for definitions of hanger nomenclature (W, H, B, TF). Refer to ESR-2523 for a complete list of all BA and HB model numbers. See Section 3.1 for a description of model numbering schemes, as they relate to intended joist dimensions and number of joist plies.

<sup>2</sup>Tabulated allowable loads must be selected based on duration of load as permitted by the applicable building code.

<sup>3</sup>The uplift loads have been increased for wind or earthquake loading with no further increase allowed. The allowable uplift loads must be reduced when other load durations govern.

<sup>4</sup>The allowable loads are based on the use of Douglas fir-Larch header material with an allowable F<sub>cL</sub> of 625 psi. For alternate header material, verify that the combination of bearing capacity and joist nails is adequate.

<sup>5</sup>Table assumes joists with F<sub>cL</sub> of 750 psi. For other joists, verify that the combination of bearing capacity and joist nails is adequate.

<sup>6</sup>Web stiffeners are required when more than two joist nails are used.

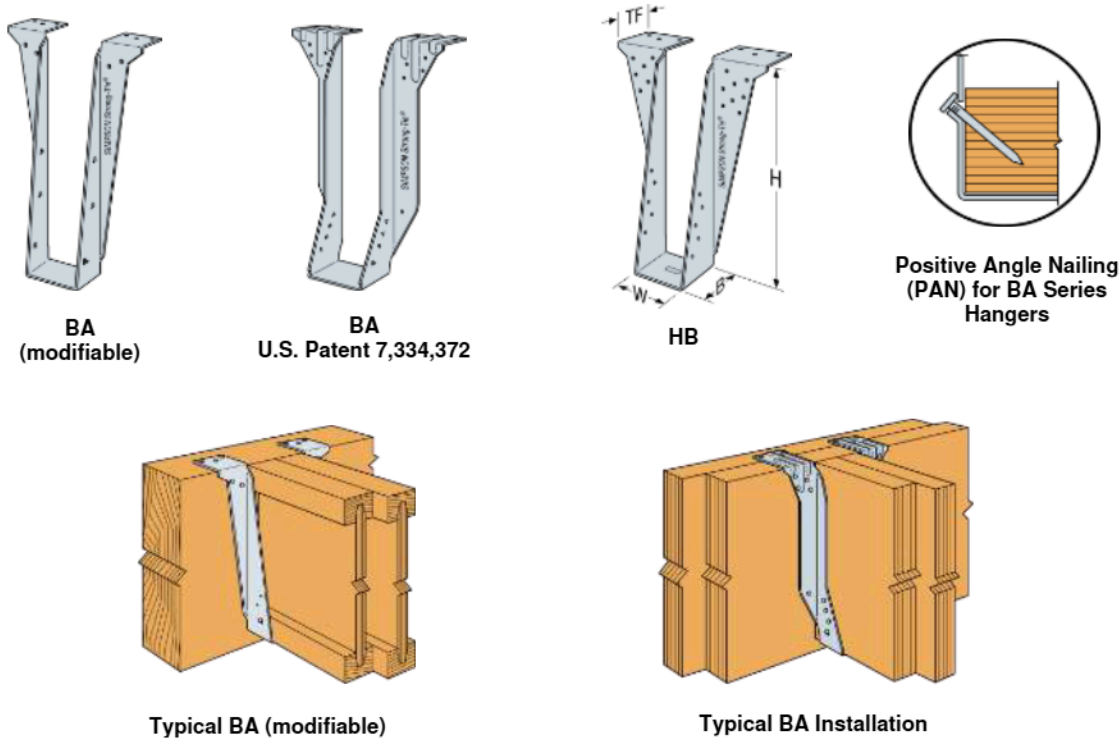

FIGURE 7— BA AND HB SERIES HANGERS

TABLE 8—ALLOWABLE LOADS FOR EGQ SERIES GIRDER HANGERS

MODEL NUMBER	HANGER DIMENSIONS <sup>1</sup> (inches)				FASTENERS (Quantity - Type)		ALLOWABLE LOADS <sup>2,6</sup> (lbs)			
	W	H <sup>4</sup>	B	TF	Face	Joist	Uplift <sup>5</sup>	Download		
							C <sub>D</sub> = 1.60	C <sub>D</sub> = 1.00	C <sub>D</sub> = 1.15	C <sub>D</sub> = 1.25
EGQ	3 <sup>5</sup> / <sub>8</sub> – 7 <sup>1</sup> / <sub>4</sub>	11 <sup>1</sup> / <sub>4</sub> - 32	6	3	28 - SDS <sup>1</sup> / <sub>4</sub> x 3	12 - SDS <sup>1</sup> / <sub>4</sub> x 3	7,670	17,085	17,085	17,085

For SI: 1 inch = 25.4 mm, 1 pound = 4.45 N.

<sup>1</sup>Refer to Figure 8 (this page) for definitions of hanger nomenclature (W, H, B, TF). Refer to ESR-2523 for a complete list of all EGQ model numbers. See Section 3.1 for a description of model numbering schemes, as they relate to intended joist dimensions and number of joist plies.

<sup>2</sup>Tabulated allowable loads must be selected based on duration of load as permitted by the applicable building code.

<sup>3</sup>Header height must be at least 11<sup>7</sup>/<sub>8</sub>".

<sup>4</sup>The "H" dimension must be specified.

<sup>5</sup>The uplift loads have been increased for wind or earthquake loading with no further increase allowed. The allowable uplift loads must be reduced when other load durations govern.

<sup>6</sup>The allowable loads are based on the use of Douglas fir-Larch header material with an allowable F<sub>cL</sub> of 625 psi and structural composite lumber joists with an allowable F<sub>cL</sub> of 750 psi. For alternate joist material, verify that the combination of bearing capacity and joist nails is adequate.

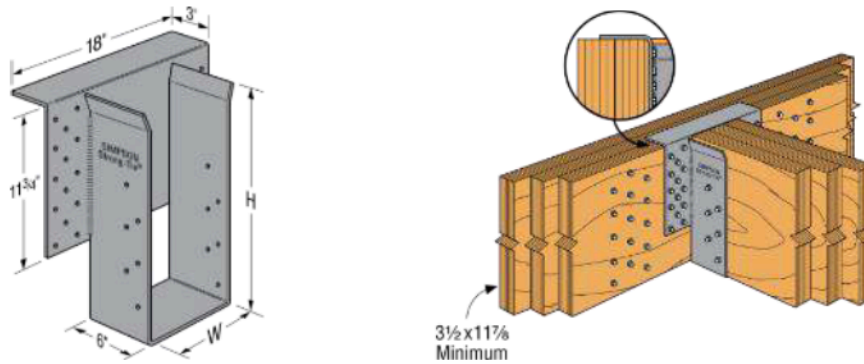

FIGURE 8—EGQ SERIES HANGERS

TABLE 9—ALLOWABLE LOADS FOR HWP AND HWPB SERIES HANGERS

Model Number	HANGER DIMENSIONS <sup>1</sup> (inches)			FASTENERS (Quantity -Type)			ALLOWABLE LOADS <sup>2,3,4,5,6</sup> (lbs)	
	W	H	B	Top	Face	Joist	Uplift	Download
							C <sub>D</sub> =1.60	C <sub>D</sub> =1.00/1.15/1.25
HWP	1 <sup>9</sup> / <sub>16</sub> - 7 <sup>1</sup> / <sub>8</sub>	5 <sup>3</sup> / <sub>8</sub> - 15 <sup>11</sup> / <sub>16</sub>	3 - 5	3 - 16d	6 - 16d	10 - 10d x 1 <sup>1</sup> / <sub>2</sub>	1,535	3,955
		15 <sup>3</sup> / <sub>4</sub> - 28		3 - 16d	6 - 16d	12 - 10d x 1 <sup>1</sup> / <sub>2</sub>	1,560	3,955
HWPB	1 <sup>9</sup> / <sub>16</sub> - 7 <sup>1</sup> / <sub>2</sub>	5 <sup>3</sup> / <sub>8</sub> - 15 <sup>11</sup> / <sub>16</sub>	3 <sup>1</sup> / <sub>4</sub> - 6 <sup>1</sup> / <sub>4</sub>	4 - 16d	8 - 16d	10 - 10d x 1 <sup>1</sup> / <sub>2</sub>	1,685	5,920
		15 <sup>3</sup> / <sub>4</sub> - 32		4 - 16d	8 - 16d	12 - 10d x 1 <sup>1</sup> / <sub>2</sub>	2,075	5,920

For SI: 1 inch = 25.4 mm, 1 lbs = 4.45 N.

<sup>1</sup>Refer to Figure 9 for definitions of hanger dimension nomenclature (W, H, B). Refer to ESR-2523 for a complete list of all HWP and HPWH model numbers. See Section 3.1 for a description of model numbering schemes, as they relate to intended joist dimensions and number of joist plies.

<sup>2</sup>Tabulated allowable loads must be selected based on duration of load as permitted by the applicable building code.

<sup>3</sup>The uplift loads have been increased for wind or earthquake loading with no further increase allowed. Reduce loads when other load durations govern.

<sup>4</sup>The allowable loads are based on the use of Douglas fir-larch header members with an allowable compression perpendicular-to-grain, F<sub>c⊥</sub>, of 625 psi, and structural composite lumber joists with an F<sub>c⊥</sub> of 750 psi. When the hangers are supported by header members having an F<sub>c⊥</sub> of less than 625 psi and/or are used to support joists having an F<sub>c⊥</sub> of less than 750 psi, it must be verified that the combination of bearing capacity and joist nail capacity is adequate.

<sup>5</sup>For welding to steel headers use <sup>3</sup>/<sub>16</sub>-inch-thick (root) by 1<sup>1</sup>/<sub>2</sub>-inch-long fillet welds for HWP models, and <sup>1</sup>/<sub>4</sub>-inch-thick (root) by 1<sup>1</sup>/<sub>2</sub>-inch-long fillet welds for HWPB models. Field welds shall be constructed and inspected in accordance with the applicable code.

<sup>6</sup>The HWP and HWPB hangers provide a torsional resistance up to a maximum joist depth of 16 inches for the HWP series and 22 inches for the HWPB series, where torsional resistance is defined as a moment of not less than 75 pounds (334 N) times the depth of the joist at which the lateral movement of the top or bottom of the joist with respect to the vertical position of the joist is 0.125 inch (3.2 mm).

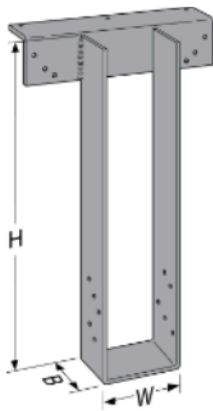

HWP

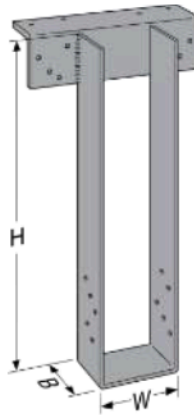

HWPB

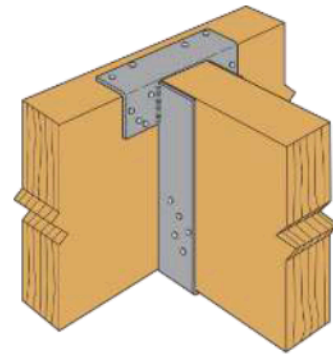

Typical HWPB Installed

FIGURE 9—HWP AND HWPB SERIES HANGERS



**DIVISION: 06 00 00—WOOD, PLASTICS, AND COMPOSITES**  
**Section: 06 05 23—Wood, Plastic, and Composite Fastenings**

**REPORT HOLDER:**

**SIMPSON STRONG-TIE COMPANY INC.**

**EVALUATION SUBJECT:**

**SIMPSON STRONG-TIE® TOP-FLANGE HANGERS FOR ENGINEERED WOOD PRODUCTS (EWP) AND GLULAM BEAMS**

**1.0 REPORT PURPOSE AND SCOPE****Purpose:**

The purpose of this evaluation report supplement is to indicate that Simpson Strong-Tie® EWP top-flange hangers used as wood framing connectors, described in ICC-ES evaluation report [ESR-2615](#), have also been evaluated for compliance with the codes noted below as adopted by the Los Angeles Department of Building and Safety (LADBS).

**Applicable code editions:**

- 2023 *City of Los Angeles Building Code* (LABC)
- 2023 *City of Los Angeles Residential Code* (LARC)

**2.0 CONCLUSIONS**

The Simpson Strong-Tie® EWP top-flange hangers used as wood framing connectors, described in Sections 2.0 through 7.0 of the evaluation report [ESR-2615](#), comply with LABC Chapter 23, and the LARC, and are subjected to the conditions of use described in this supplement.

**3.0 CONDITIONS OF USE**

The Simpson Strong-Tie® EWP top-flange hangers used as wood framing connectors, described in this evaluation report supplement must comply with all of the following conditions:

- All applicable sections in the evaluation report [ESR-2615](#).
- The design, installation, conditions of use and labeling are in accordance with the 2021 *International Building Code*® (IBC) provisions noted in the evaluation report [ESR-2615](#).
- The design, installation and inspection are in accordance with additional requirements of LABC Chapters 16 and 17, as applicable.
- The supported end of joist or beam must be within 1/4-inch from the supporting member.
- Solid blocking must be required for all joist hangers supporting roof joists having one end twisted more than one-half degree per foot of length relative to the other end, except as specifically noted in the evaluation report.
- Under the LARC, an engineered design in accordance with LARC Section R301.1.3 must be submitted.

This evaluation report supplement expires concurrently with the evaluation report, reissued December 2023.

**DIVISION: 06 00 00—WOOD, PLASTICS, AND COMPOSITES**  
**Section: 06 05 23—Wood, Plastic, and Composite Fastenings**

**REPORT HOLDER:**

**SIMPSON STRONG-TIE COMPANY INC.**

**EVALUATION SUBJECT:**

**SIMPSON STRONG-TIE® TOP-FLANGE HANGERS FOR ENGINEERED WOOD PRODUCTS (EWP) AND GLULAM BEAMS**

**1.0 REPORT PURPOSE AND SCOPE****Purpose:**

The purpose of this evaluation report supplement is to indicate that the Simpson Strong-Tie® top-flange hangers for engineered wood product (EWP) and glulam beams, described in ICC-ES evaluation report ESR-2615, have also been evaluated for compliance with the codes noted below.

**Applicable code editions:**

- 2023 *Florida Building Code—Building*
- 2023 *Florida Building Code—Residential*

**2.0 CONCLUSIONS**

The Simpson Strong-Tie® top-flange hangers for engineered wood product (EWP) and glulam beams, described in Sections 2.0 through 7.0 of ICC-ES evaluation report ESR-2615, comply with the *Florida Building Code—Building*, and the *Florida Building Code—Residential*. The design requirements must be in accordance with the *Florida Building Code—Building* or the *Florida Building Code—Residential*, as applicable. The installation requirements noted in ICC-ES evaluation report ESR-2615 for the 2021 and 2018 *International Building Code*® meet the requirements of the *Florida Building Code—Building* or the *Florida Building Code—Residential*, as applicable.

Use of the Simpson Strong-Tie® top-flange hangers for engineered wood product (EWP) and glulam beams has also been found to be in compliance with the High-Velocity Hurricane Zone provisions of the *Florida Building Code—Building*, and the *Florida Building Code—Residential* with the following condition:

- a. For connections subject to uplift, the connection must be designed for no less than 700 pounds (3114 N).

For products falling under Florida Rule 61G20-3, verification that the report holder's quality assurance program is audited by a quality assurance entity approved by the Florida Building Commission for the type of inspections being conducted is the responsibility of an approved validation entity (or the code official when the report holder does not possess an approval by the Commission).

This evaluation report supplement expires concurrently with the evaluation report, reissued December 2023.