

# ICC-ES Evaluation Report

ESR-2608

Reissued January 2024

This report also contains:



- FBC Supplement

Subject to renewal January 2025

- LABC Supplement

ICC-ES Evaluation Reports are not to be construed as representing aesthetics or any other attributes not specifically addressed, nor are they to be construed as an endorsement of the subject of the report or a recommendation for its use. There is no warranty by ICC Evaluation Service, LLC, express or implied, as to any finding or other matter in this report, or as to any product covered by the report.

Copyright © 2024 ICC Evaluation Service, LLC. All rights reserved.

<p><b>DIVISION: 06 00 00—</b> <b>WOOD, PLASTICS, AND COMPOSITES</b></p> <p><b>Section: 06 05 23—</b> <b>Wood, Plastic, and Composite Fastenings</b></p>	<p><b>REPORT HOLDER:</b> <b>SIMPSON STRONG-TIE COMPANY INC.</b></p> 	<p><b>EVALUATION SUBJECT:</b> <b>SIMPSON STRONG-TIE® STUD SHOES, PLATE TIES, WALL BRACING, JOIST BRIDGING, AND MASONRY TIES FOR WOOD CONSTRUCTION</b></p>	
---	---	---	---

## 1.0 EVALUATION SCOPE

Compliance with the following codes:

- 2021, 2018, 2015, 2012 and 2009 [International Building Code® \(IBC\)](#)
- 2021, 2018, 2015, 2012 and 2009 [International Residential Code® \(IRC\)](#)

Code sections referenced in this evaluation report are for the 2021 IBC and IRC. See Code Edition Section References table at the end of this report for code sections in earlier IBC and IRC editions.

For evaluation for compliance with codes adopted by the [Los Angeles Department of Building and Safety \(LADBS\)](#), see [ESR-2608 LABC and LARC Supplement](#).

**Property evaluated:**

Structural

## 2.0 USES

Simpson Strong-Tie® stud shoes, plate ties, wall bracing, joist bridging, and masonry ties are used as wood framing connectors in accordance with applicable sections of the IBC and IRC as follows:

### 2.1 Stud Shoe Connectors:

Simpson Strong-Tie stud shoes described in this report are used to reinforce structural studs in exterior walls or interior bearing partitions that have been cut, notched or drilled, in accordance with Sections [2308.5.9](#) and [2308.5.10](#) of the IBC, and Section [R602.6](#) of the IRC. When the size of the cut, notch, or drill hole exceeds the maximums specified in the code, the Simpson Strong-Tie stud shoes may be used provided an engineered design is submitted in accordance with Section [2302.1](#) of the IBC or Section [R301.1.3](#) of the IRC, as applicable.

### 2.2 Plate Tie Connectors:

Simpson Strong-Tie plate ties described in this report are used to connect wall top or bottom plates that have been cut to accommodate plumbing, heating or other pipes placed in or partly in the wall or partition in accordance with Section [2308.5.8](#) of the IBC and Section [R602.6.1](#) of the IRC.

### 2.3 Wall Bracing Straps:

The Simpson Strong-Tie wall bracing straps described in this report are designed to be used to resist racking during construction. The RCWB and WB/WBC brace straps are designed to brace walls and are designed to

be used as an alternate to the code prescribed nominal 1-inch-by-4-inch continuous diagonal wood brace let into studs in wood walls designated as braced wall panels according to Section [2308.6](#) of the IBC and Section [R602.10.2](#) of the IRC.

#### 2.4 Joist Bridging:

Simpson Strong-Tie bridging components described in this report are used to provide lateral support for wood joists (sawn lumber and prefabricated wood I-joists) in accordance with Section [2308.4.6](#) of the IBC and Section [R502.7.1](#) of the IRC.

#### 2.5 Masonry Ties:

Masonry Ties described in this evaluation report are used to attach anchored masonry veneer to wood framing for the purpose of transferring out of plane loads in accordance with the prescriptive requirements of TMS 402 as required by Chapters [14](#) and [21](#) of the IBC and Section [R703.8.4](#) and Table R703.8.4(1) of the IRC, or IBC Section [104.11](#) and IRC Section [R301.1](#) for alternate methods of design and construction.

### 3.0 DESCRIPTION

#### 3.1 General:

**3.1.1 [SS and HSS Stud Shoes](#):** The SS and HSS stud shoes are designed to reinforce wood studs that have been notched or bored during construction to accommodate pipes having a maximum outside diameter of  $2\frac{3}{8}$  inches (60.3 mm). The SS stud shoes provides compression load capacity for notched, cut, or drilled studs; and the HSS stud shoes provide tension (uplift) and compression load capacity for notched, cut, or drilled studs. The SS and HSS stud shoes are fabricated from No. 16 gage galvanized steel. See [Table 1](#) for model numbers; stud shoe width (W) indicating use for single, double, and triple nominally 2-inch-wide studs, single nominally 3-inch-wide studs, and single nominally 4-inch-wide studs; required fasteners; and allowable loads. See [Figure 1](#) for a drawing of overall dimensions of the SS and HSS stud shoes, and drawings of typical stud shoe installation details.

**3.1.2 [RPS \(Retrofit Plate Strap\) Tie](#):** The RPS tie is designed to reinforce top plates or sill plates of exterior walls or interior bearing walls that have been cut, drilled, or notched to accommodate plumbing, heating or other pipes placed in or partly in the wall or partition. The RPS tie is formed from No. 16 gage galvanized steel. The middle portion of the RPS tie is stamped with lines indicating the maximum span or distance of the tie permitted to span over the cut or notched portion of the plate or sill. An arrow is also stamped onto the tie to facilitate proper installation of straps when they are required at each side of the plate. See [Table 2](#) for models, tie dimensions (width and length), maximum notch width or cut in the plate or sill that specific RPS ties are designed to reinforce, required fasteners, and allowable loads. See [Figure 2](#) for a drawing of the RPS strap tie and a drawing of RPS ties installed in accordance with the prescriptive requirements of Section 2308.5.8 of the IBC, and Section R602.6.1 of the IRC, as applicable.

#### 3.1.3 Wall Bracing:

**3.1.3.1 [RCWB Brace](#):** The RCWB wall bracing straps are fabricated from No. 20 gage galvanized steel into an L-shaped angle with a series of prepunched nail holes used to fasten the brace to the wood wall studs spaced maximum 16 inches (406 mm) on center. After a maximum  $1\frac{1}{8}$ -inch (28.6 mm) deep kerf is saw-cut into the wood studs and the top and bottom wood plates and the  $1\frac{1}{16}$ -inch (27 mm) long leg of the L-shaped RCWB wall brace is inserted into the kerf, the brace is nailed to each intersecting wall stud and top and sill plate in accordance with the specified nailing schedule. See [Table 3](#) for RCWB wall bracing models, strap lengths, wall heights and brace angles measured from the horizontal [8 feet (2438 mm) at 45 degrees and 55 degrees, and 10 feet (3048 mm) at 45 degrees], and fastener schedule. See [Figure 3a](#) for a drawing of an installed RCWB wall brace, and [Figure 3b](#) for a drawing of the overall brace dimensions.

**3.1.3.2 [WB and WBC Wall Bracing](#):** The WB and WBC wall braces are fabricated from  $1\frac{1}{4}$  inch-wide (31.7 mm) No. 16 gage galvanized steel with a series of prepunched nail holes used to fasten the metal braces to the wood wall studs spaced either 16 or 24 inches (406 or 610 mm) on center. The WB and WBC wall braces resist tension loads only. Consequently, these wall braces must be installed in pairs to resist in-plane racking shear loads applied to the top of the wall. The WBC wall bracing is similar to the WB wall bracing except that it is packaged in a coil, and the coil has V-shaped notches indicating where to cut the steel strap for use as wood wall bracing. See [Table 4](#) for the WB and WBC models recognized in this report, brace lengths, wall heights and brace angles measured from the horizontal [8 feet (2438 mm) at 45 degrees and 60 degrees, and 10 feet (3048 mm) at 45 degrees], and the fastener schedule. See [Figure 4a](#) for a drawing of the WB brace, [Figure 4b](#) for the WBC brace, and [Figure 4c](#) for wall braces installed X-pairs or in opposing V-pairs.

**3.1.3.3 TWB (T-Type) Wall Bracing:** The TWB wall braces are fabricated from No. 22 gage galvanized steel into a structural T-shape brace without prepunched nail holes. The TWB wall braces resist tension and compression loads when installed in accordance with this report and when the maximum wall stud spacing is 16 inches (406 mm) on center. After a maximum  $\frac{5}{8}$ -inch (15.9 mm) deep kerf is saw-cut into the wood studs and the top and bottom wood plates and the  $\frac{9}{16}$ -inch (14.3 mm) long leg of the T-shaped TWB brace is inserted into the kerf, the brace is nailed to each intersecting wall stud and top and bottom plates in accordance with the specified nailing schedule. See [Table 5](#) for the TWB brace models recognized in this report, brace lengths, wall heights and brace angles measured from the horizontal [8 feet (2438) at 45 degrees and 55 degrees, and 10 feet (3048 mm) at 45 degrees] and required fasteners. Reference [Figure 5](#) for series drawing and [Table 5](#) for general dimensions, required fasteners and allowable loads.

**3.1.4 LTB Light Tension Bridging:** The LTB tension bridging is fabricated from No. 22 gage galvanized steel. The bridging resists tension forces only and must be installed in cross pairs. The LTB bridging devices are designed to provide lateral support of nominally 2x8 or 2x10 sawn joists spaced 16 inches on center. See [Table 6](#) for models, required fasteners, and installation requirements. See [Figure 6](#) for drawings of the LTB20 and LTB40 bridging devices, and a drawing of a typical LTB installation.

**3.1.5 NCA Series Nail-less Bridging:** The NCA bridging series are fabricated from No. 20 gage galvanized steel with the exception of the NCA2X12-16 bridging device, which is fabricated from No. 18 gage galvanized steel. The bridging devices are V-shaped along their length, and each end has sharp, jagged prongs that penetrate into the wood joists when the bridging is installed with a strong hammer blow. See [Table 7](#) for models, bridging connector lengths, and nominal joist sizes and spacings intended to be laterally braced by specific NCA bridging connectors. See [Figure 7a](#) for a drawing of a typical NCA bridging connector, and [Figures 7b](#) and [7c](#) for drawing of typical NCA bridging installations.

**3.1.6 TB Tension Bridging:** The TB tension bridging is fabricated from No. 20 gage galvanized steel, and is used to bridge sawn wood joists or prefabricated wood I-joists. Although each end of a TB tension bridge has seven nail holes, actual installation requires only two 10d-by-1 $\frac{1}{2}$  nails installed at each end. For prefabricated wood I-joists with LVL flanges, the nails must be installed perpendicular to the LVL laminations. The bridging resists tension forces only and must be installed in cross pairs. TB tension bridging is available in lengths from 20 to 60 inches (508 mm to 1524 mm). See [Table 8A](#) for TB bridging device models used with sawn wood joists at specified spacing. See [Table 8B](#) for TB tension models used to bridge prefabricated wood I-joists having depths from 9 $\frac{1}{2}$  inches (241 mm) to 32 inches (813 mm) and specified spacings. See [Figure 8](#) for a drawing of a typical TB bridging device and a drawing of I-joists bridged in a cross pair configuration showing the nails installed perpendicular to the laminations of LVL flanges.

**3.1.7 BTB, BT, and BTH Masonry Ties:** The BTB and BT Masonry Ties are used to anchor masonry veneer to wood framing with 1-inch airspace in accordance to the prescriptive requirements of corrugated sheet metal anchors in the IBC (TMS 402) and IRC. The BTB and BT Masonry Ties are also used to anchor masonry veneer for airspace of up to 2 inches, while the BTH Masonry Tie is used for airspaces of 2 to 3 inches, as shown in [Table 9](#). Simpson Strong-Tie BTB, BT, and BTH Masonry Ties are manufactured from 22-gage steel. Simpson Strong-Tie BTB, BT, and BTH Masonry Tie dimensions and typical installations are shown in [Figure 9](#).

## 3.2 Materials:

**3.2.1 Steel:** The connectors and ties described in this report are fabricated from [ASTM A653](#), SS designation, Grade 33, galvanized steel with a minimum yield strength,  $F_y$ , of 33,000 psi (227 MPa) and a minimum tensile strength,  $F_u$ , of 45,000 psi (310 MPa), except for the RPS (repair plate strap) tie series, which is fabricated from ASTM A653, SS designation, Grade 40, galvanized steel with a minimum yield strength of 40,000 psi (276 MPa) and a minimum tensile strength of 55,000 psi (379 MPa). Base metal thicknesses for the connectors and ties in this report are as follows:

NOMINAL THICKNESS (Gage)	MINIMUM BASE METAL THICKNESS (inch)
No. 16	0.0555
No. 18	0.0445
No. 20	0.0335
No. 22	0.0275

For SI: 1 inch = 25.4 mm.

The connectors and ties have a minimum G90 zinc coating specification in accordance with ASTM A653. Some models (designated with a model number ending with Z) are available with a G185 zinc coating specification in accordance with ASTM A653. Some models (designated with a model number ending with HDG) are available with a hot-dip galvanization, also known as “batch” galvanization, in accordance with [ASTM A123](#), with a minimum specified coating weight of 2.0 ounces of zinc per square foot of surface area (610 g/m<sup>2</sup>), total for both sides. Model numbers in this report do not include the Z or HDG ending, but the information shown applies. The lumber treater and the holder of this report (Simpson Strong-Tie Company) should be contacted for recommendations on the appropriate coating or material to specify for use of the steel connectors in contact with the specific proprietary-preservative-treated or fire-retardant-treated lumber.

**3.2.2 Wood:** Wood members with which the connectors are used must be either sawn lumber or engineered lumber having a minimum specific gravity of 0.50 (minimum equivalent specific gravity of 0.50 for engineered lumber), and having a maximum moisture content of 19 percent (16 percent for engineered lumber), except as noted in Section 4.1. The thickness of the supporting wood member must be equal to or greater than the length of the fasteners specified in the tables in this report, or as required by wood member design, whichever is greater. For installation in engineered wood members, minimum allowable nail spacing and end and edge distances, as specified in the applicable evaluation report for the engineered wood product, must be met.

**3.2.3 Fasteners:** Nails used for products described in Sections [3.1.1](#) through [3.1.4](#) and [3.1.6](#) and [3.1.7](#) of this report must be bright or hot-dipped galvanized carbon steel nails complying with [ASTM F1667](#), with the minimum fastener dimensions and bending yield strengths ( $F_{yb}$ ) in the following table. Alternatively, nails of other materials or finishes may be used when they are recognized in an ICC-ES Evaluation Report as having bending yield strength and withdrawal capacity equal to or greater than those of a bright carbon steel nail of the same nominal diameter.

FASTENER <sup>1</sup>	SHANK DIAMETER (inch)	NAIL LENGTH (inches)	$F_{yb}$ (psi)
6d	0.113	2	100,000
8d	0.131	2 <sup>1</sup> / <sub>2</sub>	100,000
10d x 1 <sup>1</sup> / <sub>2</sub>	0.148	1 <sup>1</sup> / <sub>2</sub>	90,000
10d	0.148	3	90,000
16d x 2 <sup>1</sup> / <sub>2</sub>	0.162	2 <sup>1</sup> / <sub>2</sub>	90,000
16d	0.162	3 <sup>1</sup> / <sub>2</sub>	90,000

For SI: 1 inch = 25.4 mm, 1 psi = 6.895 kPa.

<sup>1</sup>Nails are common unless otherwise stated.

Nails used in contact with preservative-treated or fire-retardant-treated lumber must be hot-dipped galvanized carbon steel nails complying with ASTM F1667 as required by Section [2303.6](#) of the IBC. Alternatively, nails of other materials or finishes may be used when they are recognized in an ICC-ES evaluation report for use in the applicable treated lumber and as having bending yield strengths ( $F_{yb}$ ) and withdrawal capacity equal to or greater than those of a bright carbon steel nail of the same nominal diameter as required by the evaluation report.

SDS screws used in contact with preservative-treated or fire-retardant-treated lumber must, at a minimum, comply with [ESR-2236](#). For use with treated lumber, the lumber treater or this report holder (Simpson Strong-Tie Company), or both, should be contacted for recommendations on the coating or material to specify for the fasteners as well as the connection capacities of fasteners used with the specific proprietary preservative treated or fire retardant treated lumber.

**3.2.4 Masonry Veneer Construction:** Materials and quality of masonry veneer construction must comply with the applicable provisions of Section [1403.4](#) of the 2021 and 2018 IBC, Section [1404.4](#) of the 2015 IBC or Section [R606.2](#) of the 2021, 2018 and 2015 IRC, as applicable. For materials specifically for connectors in Section [3.1.7](#) of this report, refer to Section R703.8.4 of the 2021, 2018 and 2015 IRC.

## 4.0 DESIGN AND INSTALLATION

### 4.1 Design:

The tabulated allowable loads shown in the product tables of this report are based on Allowable Stress Design (ASD) and include the load duration factor,  $C_D$ , corresponding with the applicable loads in accordance with the *National Design Specification® for Wood Construction* (NDS) and its Supplement.

Tabulated allowable loads apply to products connected to wood used under dry conditions and where sustained temperatures are 100°F (37.8°C) or less. When products are installed to wood having a moisture content greater than 19 percent (16 percent for engineered wood products), or where wet service is expected, the allowable loads must be adjusted by the applicable wet service factor,  $C_M$ , specified for lateral loads for dowel-type fasteners in the NDS. When connectors are installed in wood that will experience sustained exposure to temperatures exceeding 100°F (37.8°C), the allowable loads in this report must be adjusted by the applicable temperature factor,  $C_t$ , specified in the NDS. Connected wood members must be analyzed for load-carrying capacity at the connection in accordance with the NDS.

#### 4.2 Installation:

Installation of the connectors must be in accordance with this evaluation report and the manufacturer's published installation instructions. In the event of a conflict between this report and the manufacturer's published installation instructions, this report governs.

#### 4.3 Special Inspection:

**4.3.1 Main Wind-force-resisting Systems under the IBC:** Where required, periodic special inspection must be conducted for components within the main wind-force-resisting system in accordance with Sections [1704.2](#) and [1705.12](#) of the IBC.

**4.3.2 Seismic-Force-resisting Systems under the IBC:** Where required, periodic special inspection must be conducted for components within the seismic-force-resisting system in accordance with Sections [1704.2](#) and [1705.13](#) of the IBC.

**4.3.3 Installations under the IRC:** Special inspections are normally not required for connectors used in structures regulated under the IRC. However, for components and systems requiring an engineered design in accordance with IRC Section [R301](#), periodic special inspection requirements and exemptions must be in accordance with Sections [4.3.1](#) and [4.3.2](#) of this report.

## 5.0 CONDITIONS OF USE:

The Simpson Strong-Tie stud shoes, plate ties, wall bracing, joist bridging, and masonry ties for wood construction described in this report comply with, or are suitable alternatives to what is specified in, those codes listed in [Section 1.0](#) of this report, subject to the following conditions:

- 5.1 The connectors must be manufactured, identified and installed in accordance with this report and the manufacturer's published installation instructions. A copy of the instructions must be available at the jobsite at all times during installation.
- 5.2 When required by the code official, calculations showing compliance with this report must be submitted to the code official. The calculations must be prepared by a registered design professional where required by the statutes of the jurisdiction in which the project is to be constructed.
- 5.3 Adjustment factors noted in Section [4.1](#) and the applicable codes must be considered, where applicable.
- 5.4 Connected wood members and fasteners must comply, respectively, with Sections [3.2.2](#) and [3.2.3](#) of this report.
- 5.5 Use of connectors with preservative-treated or fire-retardant-treated lumber must be in accordance with Section [3.2.1](#) of this report. Use of fasteners with preservative-treated or fire-retardant-treated lumber must be in accordance with Section [3.2.3](#) of this report.

## 6.0 EVIDENCE SUBMITTED

Data in accordance with the [ICC-ES Acceptance Criteria for Joist Hangers and Similar Devices \(AC13\)](#), dated October 2018 (editorially revised December 2020).

## 7.0 IDENTIFICATION

- 7.1 The products described in this report are identified with a die-stamped label or an adhesive label, indicating the name of the manufacturer (Simpson Strong-Tie), the model number, and the number of an index evaluation report ([ESR-2523](#)) that is used as an identifier for the products recognized in this report.

7.2 The report holder’s contact information is the following:

**SIMPSON STRONG-TIE COMPANY INC.**  
**5956 WEST LAS POSITAS BOULEVARD**  
**PLEASANTON, CALIFORNIA 94588**  
**(800) 925-5099**  
[www.strongtie.com](http://www.strongtie.com)

CODE EDITION SECTION REFERENCES				
2021	2018	2015	2012	2009
<b>IBC</b>				
104.11	104.11	104.11	104.11	104.11
1404.6	1404.6	1404.4	1404.4	1404.4
1704.2	1704.2	1704.2	1704.2	1704
1705.12	1705.11	1705.11	1705.10	1706
1705.13	1705.12	1705.12	1705.11	1707
2302.1	2302.1	2301.2	2301.2	2301.2
2304.10.6	2304.10.5	2304.10.5	2304.9.5	2304.9.5
2308.4.6	2308.4.6	2308.4.6	2308.8.5	2308.8.5
2308.5.9	2308.5.9	2308.5.9	2308.9.10	2308.9.10
2308.5.10	2308.5.10	2308.5.10	2308.9.11	2308.9.11
2308.6	2308.6	2308.6	2308.9.3	2308.9.3
2308.5.8	2308.5.8	2308.5.8	2308.9.8	2308.9.8
<b>IRC</b>				
R301	R301	R301	R301	R301
R301.1	R301.1	R301.1	R301.1	R301.1
R301.1.3	R301.1.3	R301.1.3	R301.1.3	R301.1.3
R317.3	R317.3	R317.3	R317.3	R317.3
R502.7.1	R502.7.1	R502.7.1	R502.7.1	R502.7.1
R602.6	R602.6	R602.6	R602.6	R602.6
R602.6.1	R602.6.1	R602.6.1	R602.6.1	R602.6.1
R703.8.4	R703.8.4	R703.8.4	R703.7.4	R703.7.4

TABLE 1—SS AND HSS STUD SHOES

MODEL NO.	WIDTH (W) (in)	FASTENERS <sup>1</sup> (Quantity-Type)	ALLOWABLE LOADS <sup>2</sup> (lbs)			
			Uplift <sup>3</sup>	Download		
				C <sub>D</sub> = 1.6	C <sub>D</sub> = 1.0	C <sub>D</sub> = 1.15
SS1.5	1 <sup>9</sup> / <sub>16</sub>	12–10d x 1 1/2	—	500	500	500
SS2.5	2 <sup>9</sup> / <sub>16</sub>	12–10d x 1 1/2	—	730	740	740
SS3	3 <sup>1</sup> / <sub>16</sub>	12–10d	—	730	830	830
SS4.5	4 <sup>9</sup> / <sub>16</sub>	14–10d	—	840	840	840
HSS2-SDS1.5	1 <sup>9</sup> / <sub>16</sub>	12–SDS <sup>1</sup> / <sub>4</sub> x 1 1/2	1,025	1,165	1,165	1,165
HSS2-2-SDS3	3	12–SDS <sup>1</sup> / <sub>4</sub> x 3	1,025	1,165	1,165	1,165
HSS2-3-SDS3	4 <sup>9</sup> / <sub>16</sub>	12–SDS <sup>1</sup> / <sub>4</sub> x 3	960	990	990	990
HSS4-SDS3	3 <sup>9</sup> / <sub>16</sub>	12–SDS <sup>1</sup> / <sub>4</sub> x 3	1,025	1,205	1,205	1,205

For SI: 1 inch = 25.4 mm, 1lbs = 4.45 N.

<sup>1</sup>Fasteners are common nails for the SS stud shoes and are SDS wood screws (recognized in evaluation report [ESR-2236](#)) for the HSS stud shoes.

<sup>2</sup>Tabulated allowable loads must be selected based on duration of load as permitted by the applicable building code.

<sup>3</sup>The uplift loads have been increased for wind or earthquake loading with no further increase allowed. Tabulated allowable uplift loads must be reduced when other load durations govern.

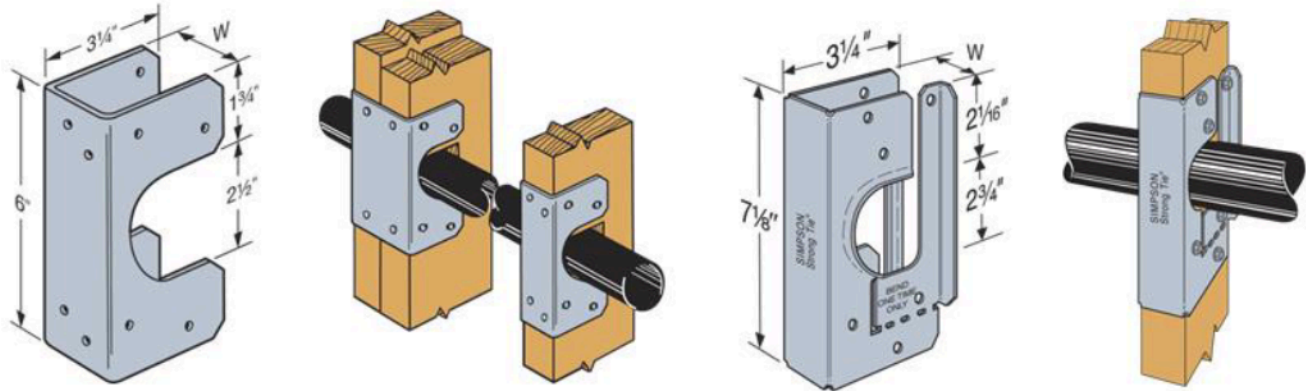

FIGURE 1—SS AND HSS STUD SHOES

TABLE 2—RPS (REPAIR PLATE STRAP) TIES

MODEL NO.	TIE DIMENSIONS (in.)		MAXIMUM NOTCH WIDTH IN WALL PLATES (inches)	FASTENERS <sup>1,2,3</sup> (Quantity–Type)	ALLOWABLE TENSION LOAD <sup>4,5</sup> (lbs) C <sub>D</sub> = 1.6
	Width	Length			
RPS18	1 1/2	18 <sup>5</sup> / <sub>16</sub>	5 1/2	12–10d x 1 1/2	1,135
				12–16d x 2 1/2	1,345
RPS22	1 1/2	22 <sup>5</sup> / <sub>16</sub>	5 1/2	12–10d x 1 1/2	1,135
				12–16d x 2 1/2	1,345
				16–10d x 1 1/2	1,510
				16–16d x 2 1/2	1,790
RPS28	1 1/2	28 <sup>5</sup> / <sub>16</sub>	12	12–10d x 1 1/2	1,135
				12–16d x 2 1/2	1,345
				16–10d x 1 1/2	1,510
				16–16d x 2 1/2	1,600

For SI: 1 inch = 25.4 mm, 1lbs = 4.45 N.

<sup>1</sup>When top plates or sill plates of exterior walls or interior bearing walls have been cut, drilled, or notched by more than 50 percent of their width, the RPS22 or 28 straps may be used to comply with the prescriptive requirements of the IRC, provided the RPS strap is placed across the opening and fastened to the wood plate at each side of opening with not less than eight 10d x 1 1/2 nails.

<sup>2</sup>Where plumbing, heating or other pipes are placed in (drilled holes in wood plates) or partly in a wood wall or partition (notched as shown in Figure 2), the RPS strap may be used to comply with the prescriptive requirements of the IBC, provided the RPS strap is fastened to each plate across and to each side of the opening with not less than six 16d x 2 1/2 nails.

<sup>3</sup>Minimum nail lengths shown. Common nails may be used.

<sup>4</sup>The loads have been increased for wind or earthquake loading with no further increase allowed. Tabulated allowable tension loads must be reduced when other load durations govern.

<sup>5</sup>For installations on both sides of the top plate, the RPS arrows should always point to the right.

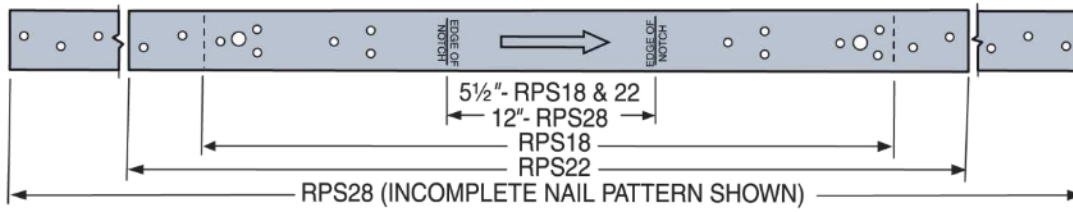

RPS (REPAIR PLATE STRAP) TIE SHOWING THE DIMENSION BETWEEN NOTCH LINES

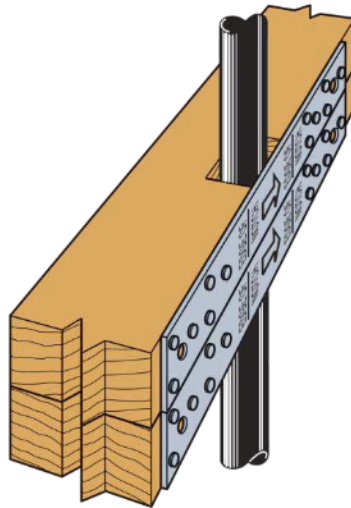

Two RPS (REPAIR PLATE STRAP) ties are fastened, one RPS tie strap for each plate of the double top plate that has been cut for plumbing, heating or other pipes placed in the wall (see footnote 2 to Table 2).

FIGURE 2—RPS (REPAIR PLATE STRAP) TIES



TABLE 3—RCWB WALL BRACING<sup>1,2,3,4</sup>

MODEL NO.	STRAP LENGTH (feet - inch)	WALL HEIGHT (feet)	REQUIRED INSTALLATION ANGLE OF THE RCWB BRACE FROM THE HORIZONTAL <sup>5</sup> (degree)	FASTENERS (Quantity-Type)	
				Top and Bottom Plates	Each Stud
RCWB12	11' - 4"	8	45°	2-16d	1-8d
RCWB12	11' - 4"	9	53°	2-16d	1-8d
RCWB14	14' - 2"	10	45°	2-16d	1-8d

For SI: 1 inch = 25.4 mm, 1 lbs = 4.45 N.

<sup>1</sup>RCWB wall bracing strap can be used as an alternate only to the code prescribed braced wall panel construction identified as a nominal 1x4 diagonal wood brace let into studs. The RCWB wall bracing strap is not recognized to replace or be used as an alternate to other braced wall construction methods described in the code.

<sup>2</sup>The allowable in-plane racking shear load of a wall braced with the RCWB strap installed in accordance with this table is 290 lbs. The RCWB strap resists tension and compression loads. The allowable 290 lbs racking shear load must not be increased for short term loading, and must not be combined with other shear resisting elements or components. Summing shear capacities of the RCWB wall brace with dissimilar materials applied to either side of the same wall is not allowed.

<sup>3</sup>The wall studs must be spaced 16 inches on center, maximum.

<sup>4</sup>A minimum 2x6 stud is required for exterior walls and interior load bearings that are braced with the RCWB strap. For interior, nonload-bearing walls braced with the RCWB strap, minimum 2x4 studs may be used.

<sup>5</sup>The RCWB wall bracing strap must be installed at the installation angle specified in the table.

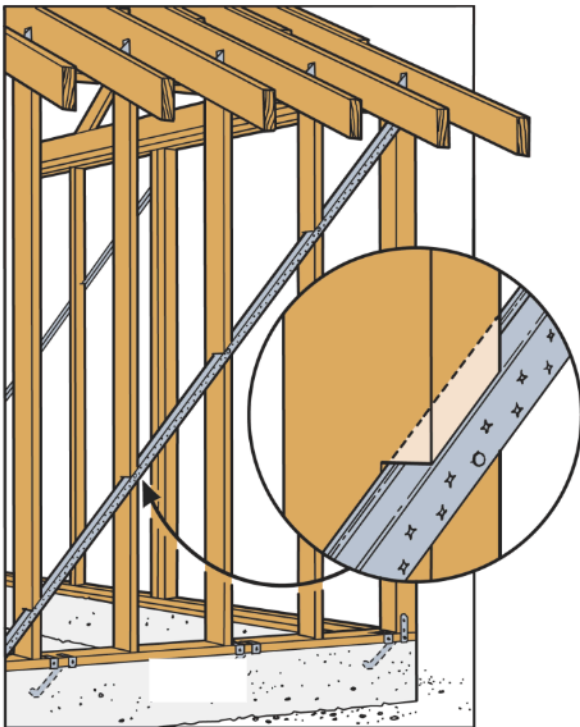

FIGURE 3A—RCWB WALL BRACING STRAP INSTALLATION  
(MAXIMUM 1<sup>1</sup>/<sub>8</sub>-INCH DEEP SAW KERF IN STUDS)

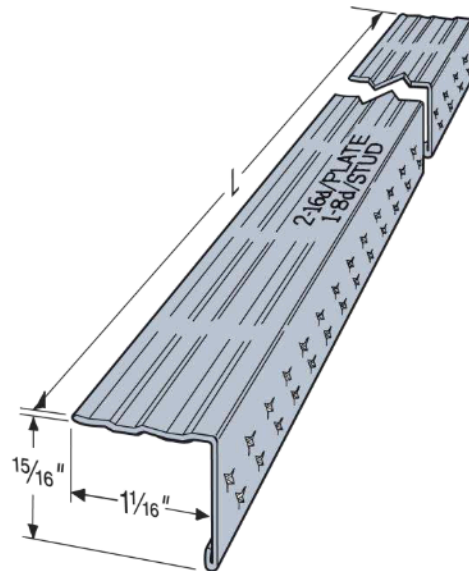

FIGURE 3B—RCWB WALL BRACING STRAP  
DIMENSIONS

TABLE 4—WB AND WBC WALL BRACING<sup>1,2,3</sup>

MODEL NO.	STRAP LENGTH (feet – inches)	WALL HEIGHT (feet)	REQUIRED INSTALLATION ANGLE OF THE WB AND WBC BRACES FROM THE HORIZONTAL <sup>4</sup> (degree)	FASTENERS (Quantity Type)	
				Top and Bottom Plates	Each Stud
WB106	9' – 5 <sup>5</sup> / <sub>8</sub> "	8	60°	2–16d	1–8d
WB126	11' – 4 <sup>3</sup> / <sub>8</sub> "	8	45°	2–16d	1–8d
WB106C	9' – 6"	8	60°	2–16d	1–8d
WB126C	11' – 4 <sup>13</sup> / <sub>16</sub> "	8	45°	2–16d	1–8d
WB143C	14' – 3"	10	45°	2–16d	1–8d

For SI: 1 inch = 25.4 mm, 1lbs = 4.45 N.

<sup>1</sup>The WB and WBC wall bracing straps can be used as alternates only to the code prescribed braced wall panel construction identified as a nominal 1x4 diagonal wood brace let into studs. The WB and WBC wall bracing straps are not recognized to replace or be used as alternates to other braced wall construction methods described in the code.

<sup>2</sup>The WB and WBC resist tension loads only. Consequently, the WB and WBC straps must be installed in pairs, as shown in Figure 4c. The allowable in-plane racking shear load of a wall braced with the WB or WBC strap installed in "X" pairs or in opposing "V" fashion is 180 lbs, and must not be combined with other shear resisting elements or components. This allowable racking shear load must not be increased for short term loading. Summing shear capacities of the WB or WBC wall braces with dissimilar materials applied to either side of the same wall is not allowed.

<sup>3</sup>The wall studs may be spaced 16 inches on center or 24 inches on center.

<sup>4</sup>The WB and WBC wall bracing straps must be installed at the installation angle specified in the table.

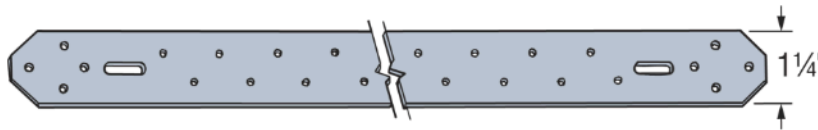
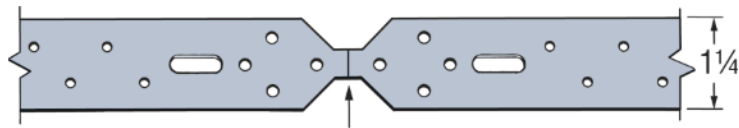

FIGURE 4A—WB Wall Brace Strap



Break off WBC at predetermined length

FIGURE 4B—WBC WALL BRACE STRAP

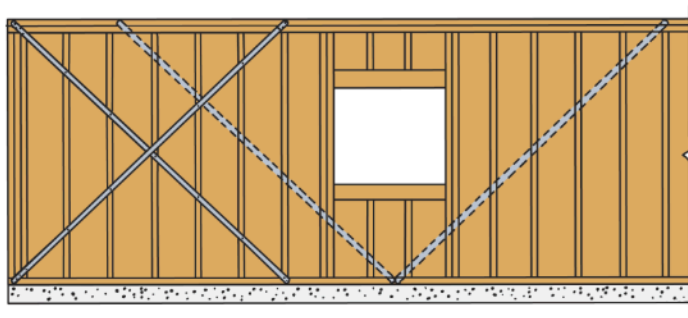

FIGURE 4C—WB AND WBC WALL BRACING "X" AND "V" APPLICATIONS

FIGURE 4—WB AND WBC WALL BRACING STRAPS

TABLE 5—TWB (T-TYPE) WALL BRACING<sup>1,2,3</sup>

MODEL NO.	BRACE LENGTH (L) (feet – inches)	WALL HEIGHT (feet)	REQUIRED INSTALLATION ANGLE OF THE TWB (T-TYPE) BRACE FROM THE HORIZONTAL <sup>4</sup> (degree)	FASTENERS (Quantity-Type)	
				Top and Bottom Plates	Each Stud
TWB10	9' – 9"	8	55°	2–16d	1–8d
TWB12	11' – 4"	8	45°	2–16d	1–8d
TWB14	14' – 2"	10	45°	2–16d	1–8d

For SI: 1 inch = 25.4 mm, 1lbs = 4.45 N.

<sup>1</sup>The TWB wall bracing strap is not recognized to replace or be used as an alternate to braced wall construction methods described in the code.

<sup>2</sup>The allowable in-plane racking shear load of a wall braced with the TWB10 strap installed in accordance with this table is 160 lbs. The allowable in-plane racking shear load of a wall braced with the TWB12 or TWB14 strap installed in accordance with this table is 190 lbs. The TWB straps resist tension and compression loads, and must not be combined with other shear resisting elements or components. The allowable racking shear load must not be increased for short term loading. Summing shear capacities of the TWB wall brace with dissimilar materials applied to either side of the same wall is not allowed.

<sup>3</sup>The wall studs must be spaced 16 inches on center, maximum.

<sup>4</sup>The TWB wall bracing strap must be installed at the installation angle specified in the table.

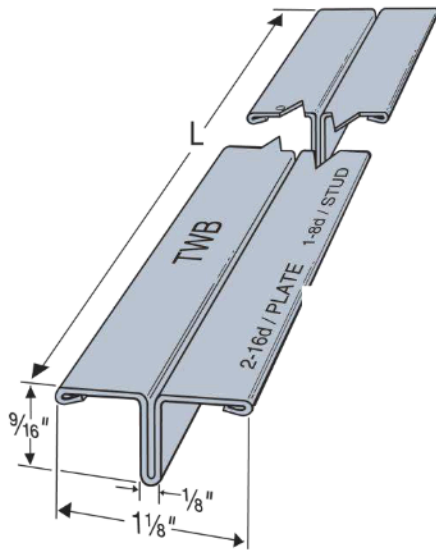

FIGURE 5A—TWB (T-TYPE) BRACE DIMENSIONS

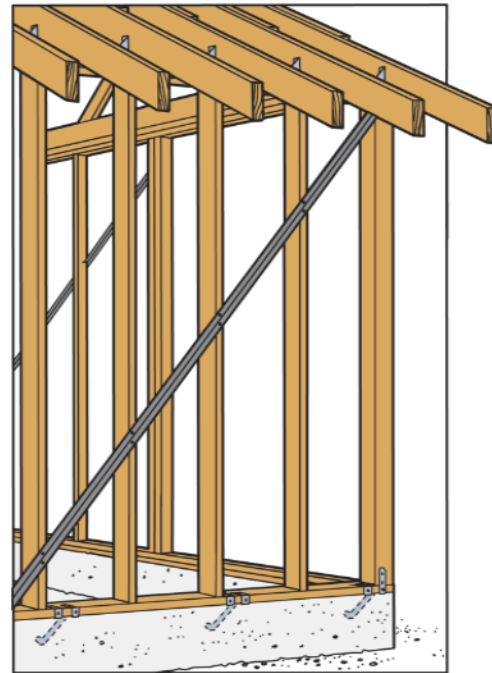

FIGURE 5B—TYPICAL TWB (T-TYPE) EXTERIOR WALL BRACE INSTALLATION (MAXIMUM 5/8-INCH DEEP SAW KERF IN STUDS)

FIGURE 5—TWB (T-TYPE) WALL BRACE

TABLE 6—LTB BRIDGING<sup>1</sup>

MODEL NO.	FASTENERS (Quantity-Type)
LTB20 <sup>2</sup>	4-6d
LTB40 <sup>3</sup>	4-6d

For SI: 1 inch = 25.4 mm.

<sup>1</sup>LTB bridging device must be installed in pairs (cross pairs as shown in Figure 6). The nominal size of joists that can be bridged with the LTB devices is either 2x8 or 2x10 spaced 16 inches on center.

<sup>2</sup>The LTB20 is installed with each end of the bridging device nailed to the top and bottom of adjacent joists as shown in Figure 6 (this page).

<sup>3</sup>The LTB40 is installed with the centerline of the bridging device bent over the middle joist and each end nailed to the adjacent joists with two 6d common nails.

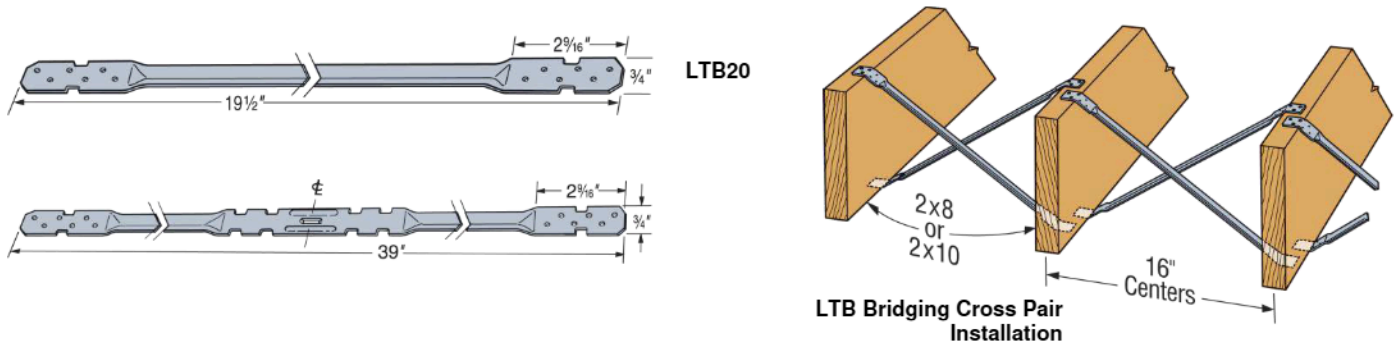

FIGURE 6—LTB BRIDGING

TABLE 7—NCA NAIL-LESS BRIDGING<sup>1,2,3</sup>

BRIDGING SERIES	MODEL NO.	BRIDGING DEVICE LENGTH (L) (inch)	NOMINAL JOIST SIZE	JOIST SPACING (inch)
NCA	NCA2 x 10-12	12 <sup>1</sup> / <sub>2</sub>	2x10	12
	NCA2 x 12-12	13 <sup>5</sup> / <sub>8</sub>	2x12	
	NCA2 x 8-16	15 <sup>1</sup> / <sub>4</sub>	2x14	
	NCA2 x 10-16	15 <sup>13</sup> / <sub>16</sub>	2x16	
	NCA2 x 8-16	15 <sup>1</sup> / <sub>4</sub>	2x8	16
	NCA2 x 10-16	15 <sup>13</sup> / <sub>16</sub>	2x10	
	NCA2 x 12-16	16 <sup>7</sup> / <sub>8</sub>	2x12	

For SI: 1 inch = 25.4 mm.

<sup>1</sup>Prongs at each end of the bridging device are driven into the wood joists with a strong hammer blow (See Figures 7a and 7b).

<sup>2</sup>The bridging devices may be installed either from the top or bottom before the sheathing is installed, or from the bottom after the sheathing is installed.

<sup>3</sup>NCA and NC bridging devices must be installed in pairs (cross pairs as shown in Figure 7c).

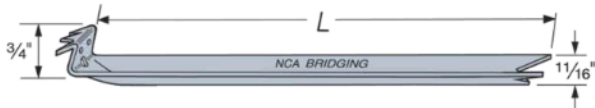

FIGURE 7A—NCA NAIL-LESS BRIDGING DEVICES

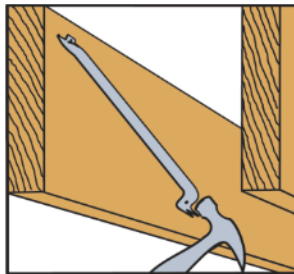

FIGURE 7B—NCA BRIDGING ARE INSTALLED FROM BELOW AS SHOWN, OR FROM ABOVE. THE UPPER END IS HAMMERED INTO THE JOIST APPROXIMATELY 1 INCH FROM THE TOP.

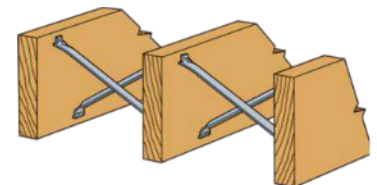

FIGURE 7C—NCA BRIDGING CROSS PAIR INSTALLATION

TABLE 8A—TB TENSION BRIDGING FOR SOLID-SAWN WOOD JOISTS<sup>1,2</sup>

MODEL NO.	BRIDGING DEVICE LENGTH (L) (inches)	NOMINAL SOLID-SAWN WOOD JOIST SIZE	JOIST SPACING (inch)	FASTENERS <sup>3</sup> (Total Quantity-Type)
TB20	20	2x8 through 2x12	12	4 - 10d x 1½
TB27	27	2x14 through 2x16	12	4 - 10d x 1½
TB27	27	2x8 through 2x16	16	4 - 10d x 1½
TB30	30	2x10 through 2x12	24	4 - 10d x 1½
TB36	36	2x14 through 2x16	24	4 - 10d x 1½

For SI: 1 inch = 25.4 mm.

<sup>1</sup>The allowable tension load is 235 lbs, which must not be increased for short term loading.

<sup>2</sup>TB bridging device must be installed in pairs (cross pairs as shown in Figure 8).

<sup>3</sup>Although each end of a TB tension bridge has seven nail holes, actual installation requires two 10d nails at each end.

TABLE 8B—TB TENSION BRIDGING FOR PREFABRICATED WOOD I-JOISTS<sup>1,2,3</sup>

I-JOIST DEPTH (in.)	I-JOIST SPACING (inches)								
	12	16	19.2	24	30	32	36	42	48
	TB BRIDGING MODEL NO.								
9½	TB20	TB27	TB27	TB30	TB36	TB36	TB42	TB48	TB54
10									
11⅞									
12									
14	TB27	TB30	TB36	TB36	TB42	TB42	TB48	TB54	TB56
16									
18									
20	TB30	TB36	TB36	TB42	TB42	TB48	TB54	TB54	TB56
22									
24	TB36	TB36	TB36	TB42	TB48	TB48	TB54	TB56	TB60
26									
28									
30									
32	TB42	TB42	TB42	TB42	TB48	TB48	TB54	TB56	TB60

For SI: 1 inch = 25.4 mm.

<sup>1</sup>The allowable tension load is 235 lbs, which must not be increased for short term loading.

<sup>2</sup>TB bridging device must be installed in pairs (cross pairs as shown in Figure 8).

<sup>3</sup>Although each end of a TB tension bridge has seven nail holes, actual installation requires only two 10d nails installed at each end, provided the nails are installed perpendicular to the laminations of LVL flanges, as shown in Figure 8.

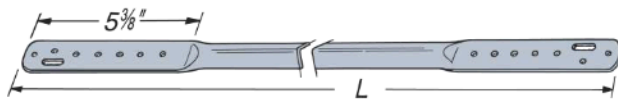

TB Bridging Device

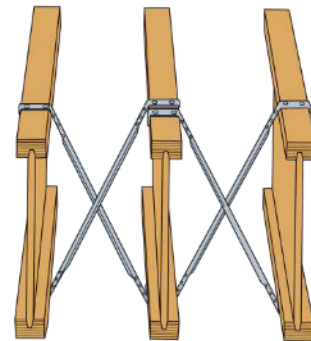

TB Bridging Installation

FIGURE 8—TB TENSION BRIDGING

TABLE 9—MASONRY TIES

Model No.	Fastener (in.)	Airspace	Max. Wall Area (sq. ft) Supported per Tie	Maximum Vertical Tie Spacing (in.)	
				Installation on Every Stud (16" o.c.)	Installation on Every Other Stud (32" o.c.)
BTB and BT	1 - 8d x 2½	1"	2.67 <sup>5</sup>	24	12
		> 1" to ≤ 2"	2.00 <sup>6</sup>	18	9
BTH	1 - 8d x 2½	≥ 2" to ≤ 3"	2.67 <sup>5</sup>	24	12

For SI: 1 inch = 25.4 mm

<sup>1</sup> 1" airspace based on table R703.8.4(1) in 2021 and 2018 IRC; airspaces larger than 1" are based on testing per Annex 2 of the ICC-ES Acceptance Criteria for Joist Hangers and Similar Devices (AC13).

<sup>2</sup> The Spacing does not pertain to applications where wind pressures exceed 30 psf, or in seismic design categories listed in Section R703.8.4, 2021 and 2018 IRC.

<sup>3</sup> Embedment and cover for all ties per TMS 402 Section 12.2.2.5.1.2 or 2021 and 2018 IRC Section R703.8.4.

<sup>4</sup> BTH maximum vertical offset from center of nail to the bottom of the horizontal leg is 1" for airspaces up to and including 2¾", and ¾" for airspaces greater than 2¾" and up to 3".

<sup>5</sup> Spacing around openings: for openings greater than 16 in. in either direction, additional anchors are required in accordance with TMS 402 Section 12.2.2.5.6.4 or 2021 and 2018 IRC Section 703.8.4.1.1.

<sup>6</sup> Spacing around openings: for openings greater than 16 in. in either direction, additional anchors are required around the opening perimeter spaced not more than 19in. o.c. and must be placed within 12 in. of the opening.

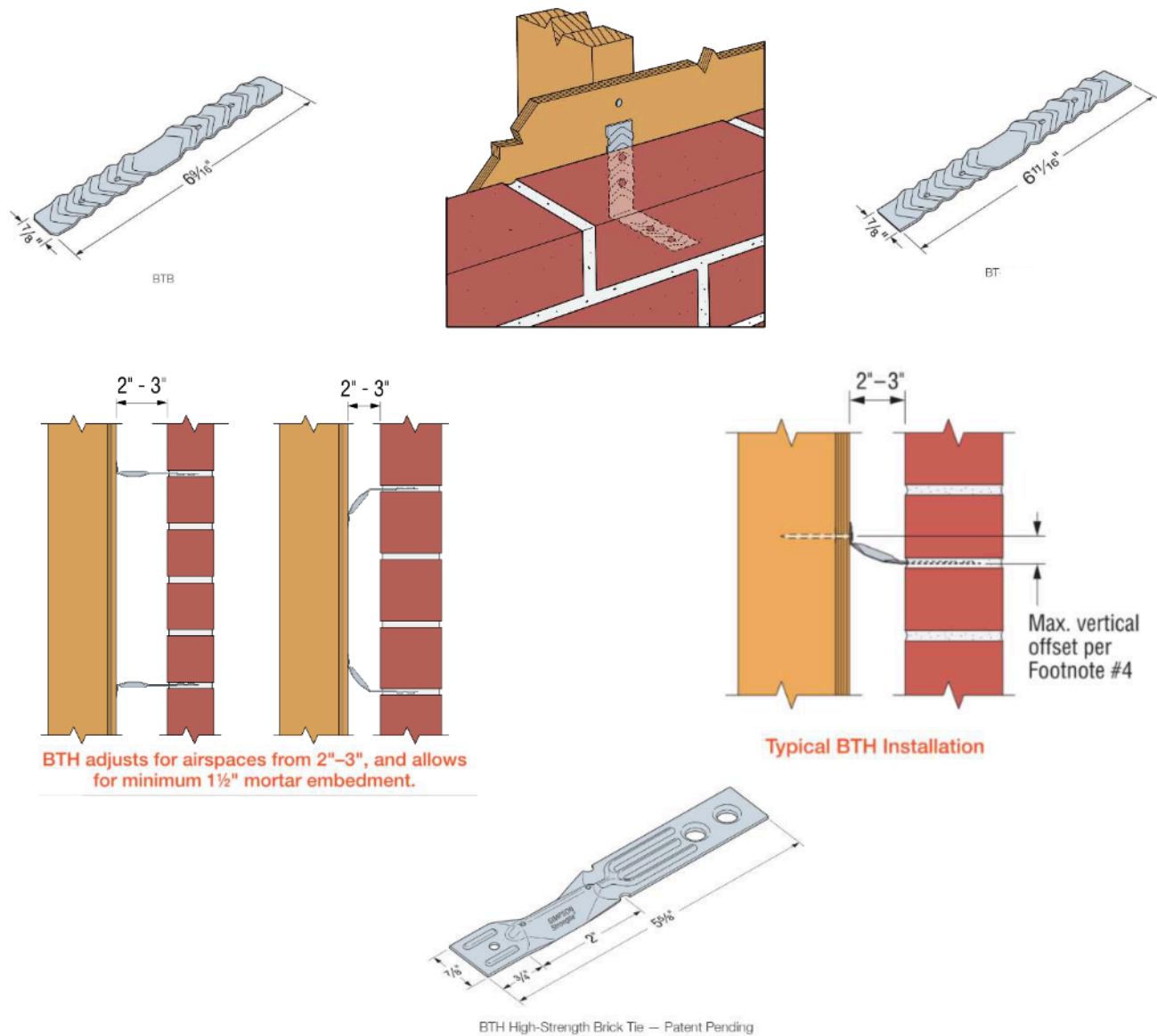

BTH adjusts for airspaces from 2"-3", and allows for minimum 1½" mortar embedment.

Typical BTH Installation

FIGURE 9—MASONRY TIES

DIVISION: 06 00 00—WOOD, PLASTICS AND COMPOSITES  
Section: 06 05 23—Wood, Plastic, and Composite Fastenings

**REPORT HOLDER:**

SIMPSON STRONG-TIE COMPANY INC.

**EVALUATION SUBJECT:**

SIMPSON STRONG-TIE® STUD SHOES, PLATE TIES, WALL BRACING, JOIST BRIDGING, AND MASONRY TIES FOR WOOD CONSTRUCTION

**1.0 REPORT PURPOSE AND SCOPE****Purpose:**

The purpose of this evaluation report supplement is to indicate that Simpson Strong-Tie® stud shoes, plate ties, wall bracing, joist bridging, and masonry ties for wood construction, described in ICC-ES evaluation report [ESR-2608](#), have also been evaluated for compliance with the codes noted below as adopted by the Los Angeles Department of Building and Safety (LADBS).

**Applicable code editions:**

- 2023 *City of Los Angeles Building Code* (LABC)
- 2023 *City of Los Angeles Residential Code* (LARC)

**2.0 CONCLUSIONS**

The Simpson Strong-Tie® stud shoes, plate ties, wall bracing, joist bridging, and masonry ties for wood construction, described in Sections 2.0 through 7.0 of the evaluation report [ESR-2608](#), comply with the LABC Chapters 14, 21 and 23, and the LARC, and are subjected to the conditions of use described in this supplement.

**3.0 CONDITIONS OF USE**

The Simpson Strong-Tie® stud shoes, plate ties, wall bracing, joist bridging, and masonry ties for wood construction, described in this evaluation report supplement must comply with all of the following conditions:

- All applicable sections in the evaluation report [ESR-2608](#).
- The design, installation, conditions of use and labeling are in accordance with the 2021 *International Building Code*® (2021 IBC) provisions noted in the evaluation report [ESR-2608](#).
- The design, installation and inspection are in accordance with additional requirements of LABC Section 1402.3, Chapters 16 and 17, as applicable.
- Allowable loads must be reduced when load duration with lower value  $C_D$  (than what is in the tables) governs.
- Under the LARC, an engineered design in accordance with LARC Section R301.1.3 must be submitted.

This supplement expires concurrently with the evaluation report, reissued January 2024.

DIVISION: 06 00 00—WOOD, PLASTICS AND COMPOSITES  
Section: 06 05 23—Wood, Plastic, and Composite Fastenings

**REPORT HOLDER:**

SIMPSON STRONG-TIE COMPANY INC.

**EVALUATION SUBJECT:**

SIMPSON STRONG-TIE® STUD SHOES, PLATE TIES, WALL BRACING, JOIST BRIDGING, AND MASONRY TIES FOR WOOD CONSTRUCTION

**1.0 REPORT PURPOSE AND SCOPE****Purpose:**

The purpose of this evaluation report supplement is to indicate that the Simpson Strong-Tie® stud shoes, plate ties, wall bracing, joist bridging, and masonry ties, described in ICC-ES evaluation report ESR-2608, have also been evaluated for compliance with the codes noted below.

**Applicable code editions:**

- 2023 Florida Building Code—Building
- 2023 Florida Building Code—Residential

**2.0 CONCLUSIONS**

The Simpson Strong-Tie® stud shoes, plate ties, wall bracing, joist bridging, and masonry ties, described in Sections 2.0 through 7.0 of ICC-ES evaluation report ESR-2608, comply with the *Florida Building Code—Building*, and the *Florida Building Code—Residential*. The design requirements are determined in accordance with the *Florida Building Code—Building* or the *Florida Building Code—Residential*, as applicable. The installation requirements noted in ICC-ES evaluation report ESR-2608 for the 2021 and *International Building Code*® meet the requirements of the *Florida Building Code—Building* or the *Florida Building Code—Residential*, as applicable.

Use of the Simpson Strong-Tie® stud shoes, plate ties, wall bracing, joist bridging, and masonry ties has also been found to be in compliance with the High-Velocity Hurricane Zone provisions of the *Florida Building Code—Building*, and the *Florida Building Code—Residential* with the following condition:

- a. For connections subject to uplift, the connection must be designed for no less than 700 pounds (3114 N).

For products falling under Florida Rule 61G20-3, verification that the report holder's quality assurance program is audited by a quality assurance entity approved by the Florida Building Commission for the type of inspections being conducted is the responsibility of an approved validation entity (or the code official when the report holder does not possess an approval by the Commission).

This supplement expires concurrently with the evaluation report, reissued January 2024.