

WP/HWP/HWPH

High-Capacity Top-Flange Hangers

The WP, HWP and HWPH series are designed to support joists on wood purlins or beams.

The HWP and HWPH high-wind purlin hangers have enhanced uplift and are ideal for high-wind applications.

Material: (Top flange/stirrup): WP — 7/12 gauge; HWP — 7/12 gauge; HWPH — 3/7 gauge

Finish: Simpson Strong-Tie gray paint; HDG available

Installation:

- Use all specified fasteners.
- The WP, HWP and HWPH may be used for weld-on applications. The minimum size weld is a 1½" long fillet weld to each side of the top flange; weld size to match hanger material thickness. See p. 20, note k for weld information. Weld-on applications have the maximum allowable capacity listed. For WP, uplift loads do not apply to this application. For additional load information, refer to technical bulletin T-C-WELDUPLFT at strongtie.com.
- Non-modified hangers can support joists sloped up to ¼:12 using table loads. For joists sloping between ¼:12 and ¾:12 use 85% of the table loads. See technical bulletin T-C-SLOPEJUST at strongtie.com.
- Web stiffeners are required for these hangers.
- If joist is shorter than hanger by more than ½" use only 50% of the table loads.
- For attaching to multi-ply headers, refer to technical bulletin T-C-MPLYHEADR at strongtie.com.

Options:

- HWP and HWPH may be sloped up to 45° and/or may have a sloped and/or skewed seat up to 45°. WP skewed up to 84°. See p. 179 for reduction associated with modifications.
- The top flange of the WP, HWP and HWPH may be offset and/or sloped down up to 35°. The top flange may also be opened/closed up to 30°. See p. 179 for reduction associated with modifications.
- All models are available in Type A (joist bevel cut up to 45°). See p. 179. WP is also available in Type B style (square-cut joist). Contact Simpson Strong-Tie when ordering.
- Hangers with a skew greater than 15° may have all the joist nails on the outside angle.
- Specify the slope up or down in degrees from the horizontal plane and/or the skew right or left in degrees from the perpendicular vertical plane.
- When combining skews and slopes specify whether low side, high side, or center of joist will be flush with the top of the header (see illustration on p. 179).

Ridge Hanger (WP only)

- Top flange may be sloped to a maximum of 35° to accommodate a ridge (see illustration). Specify angle of the slope. Reduce allowable load using straight-line interpolation. See open/closed example.

Saddle Hanger (WPD)

- WPD saddle hanger allowable loads are WP loads for each stirrup. Saddle hangers on stud walls do not achieve catalog loads.
- Recommended S dimension is ¼" oversized for carrying members 2½" wide and less or ½" oversized for greater than 2½" wide.

Codes: See p. 13 for Code Reference Key Chart

Web Applications: Visit app.strongtie.com/hs to access our Hanger Selector web application.

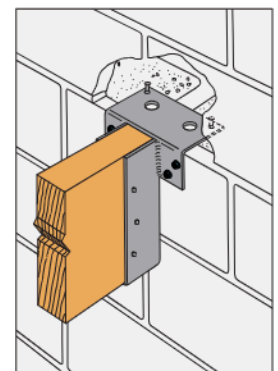
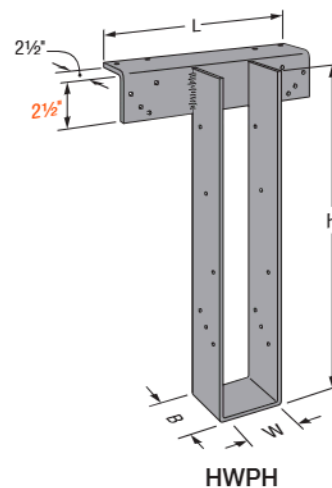
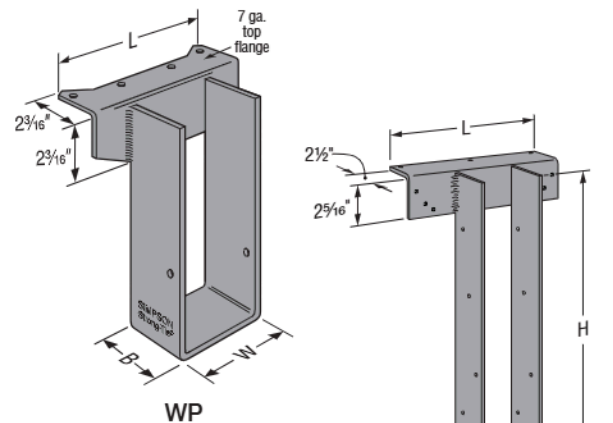

WMU Mid-Wall Installation
See pp. 250–251 for models and more information.

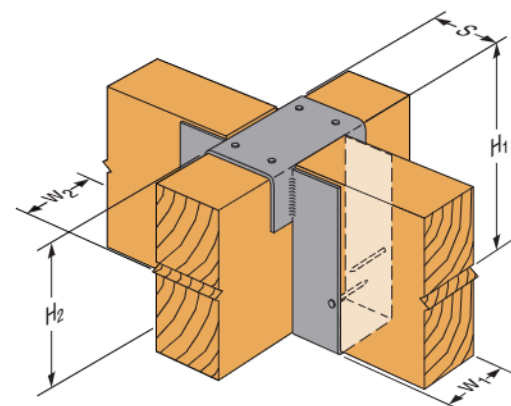

Typical WPD Saddle Hanger Installation

WP/HWP/HWPH

High-Capacity Top-Flange Hangers (cont.)

I-Joist, Glulam and Structural Composite Lumber Connectors

Model	Stirrup Width (W) (in.)	Stirrup Seat Depth (B) (in.)	Top Flange Length (L) (in.)
WP	1 ⁹ / ₁₆ – 2 ¹ / ₁₆	See load table	7
	2 ¹ / ₁₆ – 3 ³ / ₁₆	2 ¹ / ₂	7
	3 ¹¹ / ₁₆ – 7 ¹ / ₁₆	2 ¹ / ₂	8
	7 ³ / ₁₆ – 7 ¹ / ₂	2 ¹ / ₂	10
HWP	1 ⁹ / ₁₆	5	10
	1 ¹³ / ₁₆	4	10
	2 ³ / ₁₆ – 5 ³ / ₁₆	3	10
	5 ¹ / ₁₆ – 7 ¹ / ₁₆	3	12
HWPH	1 ¹³ / ₁₆ – 2 ¹ / ₂	See load table	10
	2 ³ / ₁₆ – 2 ³ / ₄	4	10
	3 ¹ / ₄ – 3 ³ / ₁₆	3 ¹ / ₄	10
	3 ¹³ / ₁₆ – 6 ³ / ₄	3 ¹ / ₄	12
	6 ¹³ / ₁₆ – 7 ¹ / ₂	3 ¹ / ₄	14



Visit app.strongtie.com/hs to access our Hanger Selector web application.

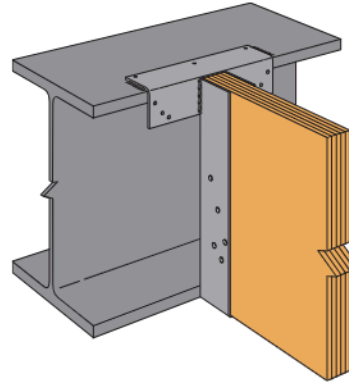

HWP Welded on Steel Flange
For welded applications, see technical bulletin T-C-WELDUPLFT at strongtie.com.

Model	Nailer	Fasteners (in.)		Uplift ¹ (160)	Allowable Down Loads		
		Header	Joist		DF/SP	SPF/HF	LSL
WP	2x	(4) 0.148 x 1 1/2	(2) 0.148 x 1 1/2	—	2,465	1,985	3,150
	(2) 2x	(4) 0.148 x 2 1/2	(2) 0.148 x 1 1/2	—	2,985	2,230	—
	3x or 4x	(4) 0.162 x 2 1/2	(2) 0.148 x 1 1/2	—	2,985	2,230	3,375
HWP	(2) 2x	(9) 0.148 x 3	(10) 0.148 x 1 1/2	710	4,415	3,860	4,415
	3x	(9) 0.162 x 2 1/2	(10) 0.148 x 1 1/2	970	4,415	3,860	—
	4x	(9) 0.162 x 2 1/2	(10) 0.148 x 1 1/2	1,535	4,920	3,860	4,920
HWPH	(2) 2x	(12) 0.162 x 2 1/2	(10) 0.148 x 1 1/2	710	5,910	4,820	5,910
	3x	(12) 0.162 x 2 1/2	(10) 0.148 x 1 1/2	970	5,970	5,125	—
	4x	(12) 0.162 x 3 1/2	(10) 0.148 x 1 1/2	1,550	5,970	5,125	5,970

- Attachment of nailer to supporting member is the responsibility of the designer.
- Uplift loads are based on DF/SP lumber. For SPF/HF, use 0.86 x DF/SP uplift load.
- Fasteners:** Nail dimensions are listed diameter by length. See pp. 23–24 for fastener information.

Nailer Table

The table indicates the maximum allowable loads for WP, HWP and HWPH hangers used on wood nailers. Nailers are wood members attached to the top of a steel I-beam, concrete or masonry wall.

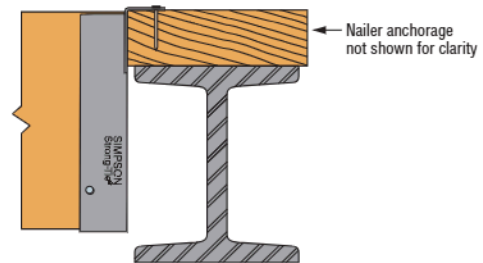

Installation on Wood Nailer

Various Header Applications

Model	Joist (in.)		Fasteners (in.)			Allowable Loads Header Type							Code Ref.
	Width	Depth	Top	Face	Joist	Uplift (160)	LVL	PSL	LSL	DF/SP	SPF/HF	I-Joist	
WP	1 1/2 to 7 1/2	5 3/8 to 30	(4) 0.148 x 1 1/2	—	(2) 0.148 x 1 1/2	—	2,935	3,150	—	2,465	1,985	2,030	IBC®, FL, LA
	1 1/2 to 7 1/2	5 3/8 to 30	(4) 0.148 x 2 1/2	—	(2) 0.148 x 1 1/2	—	2,935	3,150	3,150	2,985	2,230	—	
	1 1/2 to 7 1/2	5 3/8 to 30	(4) 0.162 x 2 1/2	—	(2) 0.148 x 1 1/2	—	3,095	3,605	3,605	2,985	2,230	—	
HWP	1 1/2 to 7	6 to 15 3/8	(3) 0.162 x 3 1/2	(6) 0.162 x 3 1/2	(10) 0.148 x 1 1/2	1,535	3,995	4,500	4,350	3,955	3,955	—	
	1 1/2 to 7	15 3/4 to 28	(3) 0.162 x 3 1/2	(6) 0.162 x 3 1/2	(12) 0.148 x 1 1/2	1,560	3,995	4,500	4,350	3,955	3,955	—	
HWPH	1 ¹³ / ₁₆ to 7 ¹ / ₂	6 to 15 ³ / ₈	(4) 0.162 x 3 ¹ / ₂	(8) 0.162 x 3 ¹ / ₂	(10) 0.148 x 1 ¹ / ₂	1,685	6,595	7,025	5,450	5,920	4,740	—	
	1 ¹³ / ₁₆ to 7 ¹ / ₂	15 ³ / ₄ to 32	(4) 0.162 x 3 ¹ / ₂	(8) 0.162 x 3 ¹ / ₂	(12) 0.148 x 1 ¹ / ₂	2,075	6,595	7,025	5,450	5,920	4,740	—	

- Uplift loads have been increased for earthquake or wind loading with no further increase allowed. Reduce where other loads govern.
- Uplift loads are based on DF/SP lumber. For SPF/HF, use 0.86 x DF/SP uplift load except WMU, use 0.75 x DF/SP uplift loads.
- LVL headers are assumed to be made primarily from Douglas fir or southern pine. For LVL made from spruce-pine-fir or similar less-dense veneers, use the values found in the SPF/HF column.
- For hanger heights exceeding the joist height, the allowable load is 0.50 of the table load.
- Fasteners:** Nail dimensions are listed diameter by length. Titen Turbo™ screws are Simpson Strong-Tie concrete and masonry screws. See pp. 23–24 for fastener information.

WP/HWP/HWPH

High-Capacity Top-Flange Hangers (cont.)

Modifications and Associated Load Reductions for WP/HWP/HWPH

Models	Seat						Top Flange				Top Flange and Seat				Joist Height Joist Shorter Than Hanger	
	Seat Sloped 45° Max.		Seat Skewed Type A	Seat Skewed Type B		Seat Sloped and Skewed Type A 1°-45°		Top Flange Sloped 35° Max.	Top Flange Bent Open or Closed 30° Max.	Top Flange Offset		Top Flange Offset and Skewed Seat Type A, Bevel Cut 1°-45°		Top Flange Offset and Skewed Seat Type B, Plumb Cut 1°-84°		
	Slope Up	Slope Down	1°-45°	1°-45°	46°-84°	Up	Down			Narrow	Wide	Narrow	Wide	Narrow		Wide
WP		1.0		1.0			1.0	(90-a)/90	(90-a)/90	0.5		0.5		0.25	0.3	By more than ½": 0.50 By ½" or less: 1.00
HWP	1.0		1.0	N/A		1.0	0.8			0.5	0.6	0.5	0.6	N/A		
HWPH		0.8		0.8	0.7		0.8								0.5	

1. For straight-line interpolation, "a" is the specified angle.
2. Reduction factors are not cumulative. Use the lowest factors that apply.
3. Narrow ≤ 3½", Wide > 3½".
4. HWP and HWPH options receive catalog uplift loads except: top flange offset 30% of the table load, skewed type A is 75% of the table load and HWPH only skewed type B is 50% of the table load.
5. Top flange bent closed is not available for HWP or HWPH.

Reduction Factor Instructions

Allowable Download = (lowest of Seat, Top Flange, or Joist Height) × (Table Load)

Allowable Uplift = as noted in table per height.

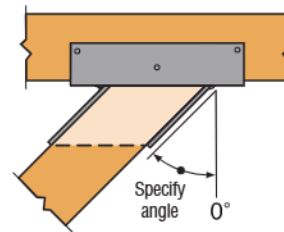

**HWP Top View
Skewed Left Type A Hanger**
(bevel-cut joist shown)

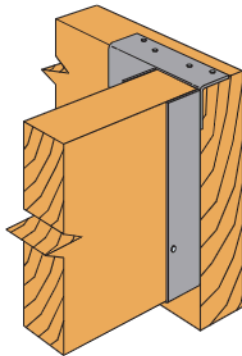

**Typical WP Top Flange
Offset Left**

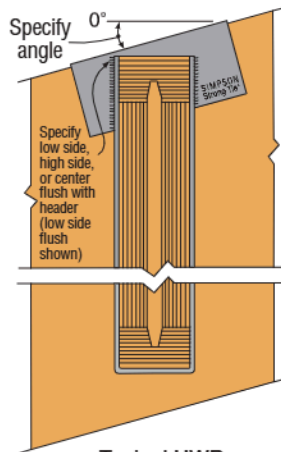

**Typical HWP
Top Flange Sloped Down
Left with Low Side Flush**

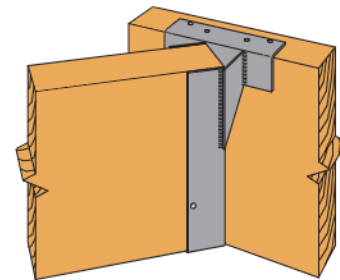

**WP Skewed Left
Type B Hanger**
(square-cut joist shown)

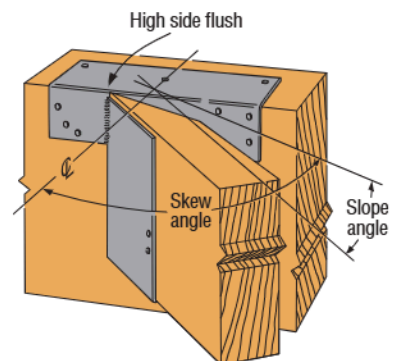
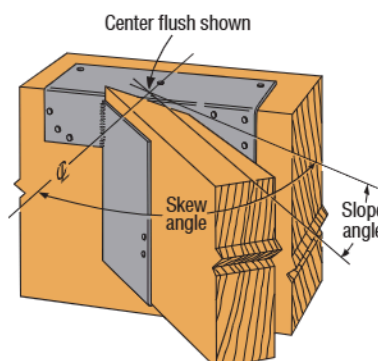
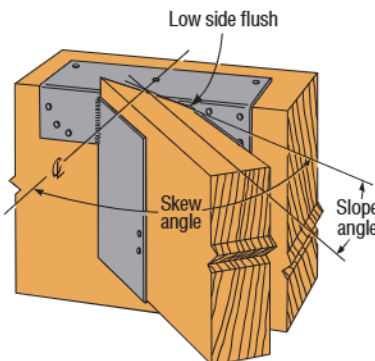

Typical HWP sloped down, skewed right with type A hanger (joist end must be bevel cut).
When ordering, specify low side flush, center flush or high side flush.